



ARI-STOBU® - Stop valve with gland seal

ARI-STOBU® Globe valve with flanges

- TRB 801 No.45 (except GG-25)
- German "TA-Luft" TÜV-Test-No. 922-9204866 (optional)

Cast iron
Nodular iron
BR 006/306

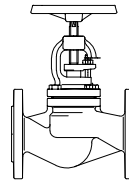

Page 2

ARI-STOBU® Globe valve with flanges

- TRB 801 No.45
- Test approvals TÜ.A./TÜV.AR.187-00
- German "TA-Luft" TÜV-Test-No. 922-9204866 (optional)

Cast steel
BR 006/306

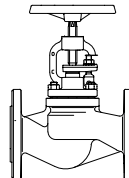

Page 2

ARI-STOBU® Globe valve with flanges

- TRB 801 No.45
- Test approvals TÜ.A./TÜV.AR.187-00
- German "TA-Luft" TÜV-Test-No. 922-9204866 (optional)

Forged steel
BR 006

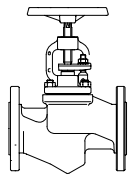

Page 3

ARI-STOBU® Globe valve with flanges

- TRB 801 No.45
- German "TA-Luft" TÜV-Test-No. 922-9204866 (optional)

Stainless steel
BR 006

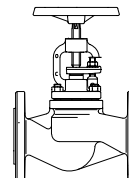

Page 3

ARI-STOBU® Globe valve with butt weld ends

- TRB 801 No.45
- Test approvals TÜ.A./TÜV.AR.187-00
- German "TA-Luft" TÜV-Test-No. 922-9204866 (optional)

Forged steel
BR 005

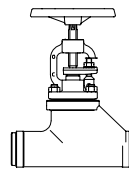

Page 5

ARI-STOBU® Globe valve with butt weld ends

- TRB 801 No.45
- Test approvals TÜ.A./TÜV.AR.187-00
- German "TA-Luft" TÜV-Test-No. 922-9204866 (optional)

Cast steel
BR 005

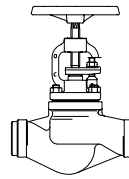

Page 4

ARI-STOBU® Y-pattern globe valve with flanges

- TRB 801 No.45
- German "TA-Luft" TÜV-Test-No. 922-9204866 (optional)

Stainless steel
BR 009

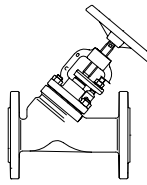

Page 5

ARI-STOBU® Angle pattern globe valve with flanges

- TRB 801 No.45 (except GG-25)
- German "TA-Luft" TÜV-Test-No. 922-9204866 (optional)

Cast iron
Nodular iron
BR 007/307

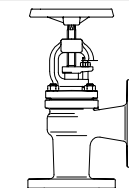

Page 6

ARI-STOBU® Angle pattern globe valve with flanges

- TRB 801 No.45
- Test approvals TÜ.A./TÜV.AR.187-00
- German "TA-Luft" TÜV-Test-No. 922-9204866 (optional)

Cast steel
BR 007/307

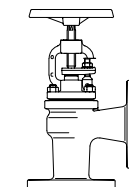

Page 6

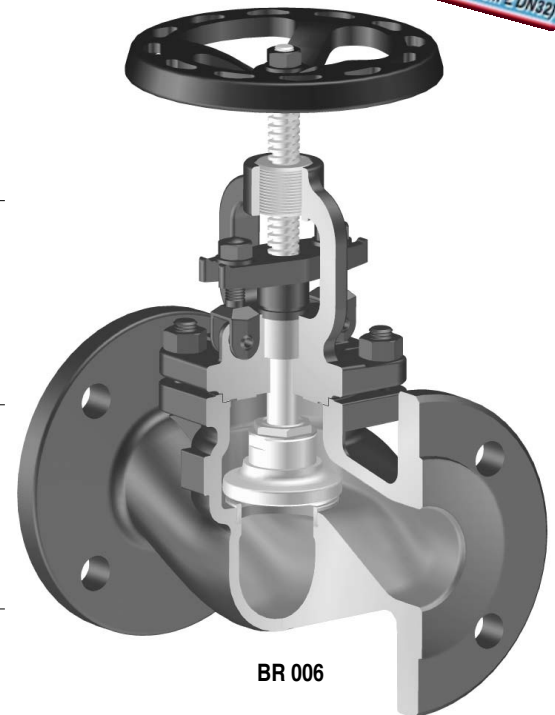

BR 006

Features:

- Proven technology
- Solid plug made of stainless material
- Solid stem made of stainless material
- Solid seat made of stainless material
- Stem with roll hardened thread
- Burnished stem
- High-tensile gland packing
- Favourable Zeta-values

In cast steel, forged steel and stainless steel:

- Bonnet top with threaded bushing
- Pivot mounted bolts

ARI-STOBU® - Stop valve with gland seal, made of cast iron and nodular iron

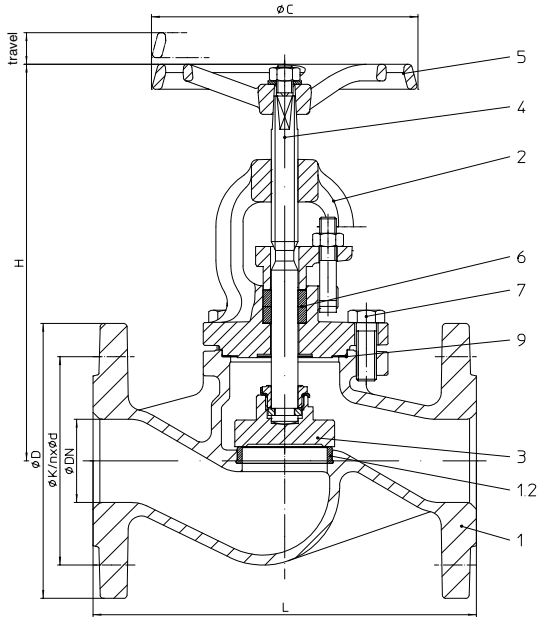

Figure	Nominal pressure	Material	Nominal diameters
12.006	PN 16	GG-25	DN 15-300
12.306			
22.006	PN 16	GGG-40.3	DN 15-350
22.306			
23.006	PN 25	GGG-40.3	DN 15-150
23.306			
BR 306: Trim made of RG/MS (CuZn35Ni3Mn2AlPb, CW710R code number 02 CuSn10-Cu, CC480K code number 03)			
Test:	DN 15-300 optional:	German "TA-Luft" TÜV-Test-No. 922-9204866 (refer to page 14)	

Selection of possible applications:

- Industry
- Powerstations
- Flue gas purification plant
- Vapour facilities
- Recycling facilities
- Shipbuilding
- General plant manufacturing

- other applications on request -

Weights (kg)

Figure-No.	DN	15	20	25	32	40	50	65	80	100	125	150	200	250	300	350	400	500
12.006 / 12.306		3,5	4,0	5,0	6,8	9,3	12,2	18,0	24,5	35,0	55,0	77,0	145,0	243,0	341,0	--	--	--
22.006 / 22.306		3,9	4,3	5,4	7,0	9,5	12,9	18,4	24,5	36,0	56,0	78,0	122,0	247,0	336,0	451,0	--	--
23.006 / 23.306		3,9	4,3	5,4	7,0	9,5	12,9	18,4	24,5	36,0	56,0	78,0	122,0	--	--	--	--	--

ARI-STOBU® - Stop valve with gland seal, made of cast steel

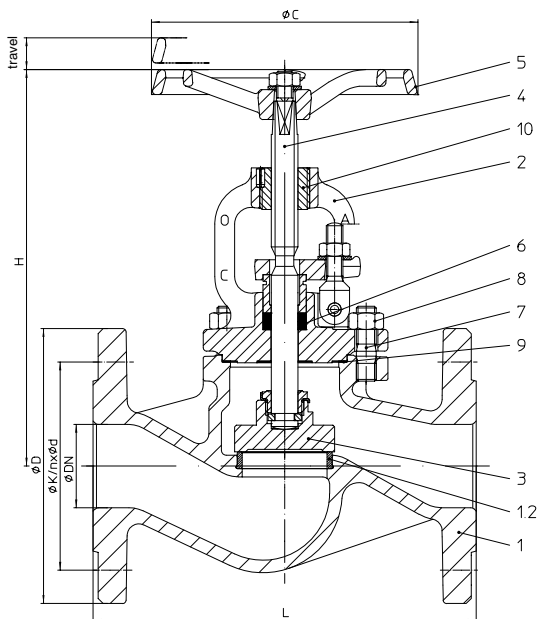

Figure	Nominal pressure	Material	Nominal diameters
34.006	PN 25	1.0619+N	DN 15-500
34.306			
35.006	PN 40	1.0619+N	DN 15-500
35.306			
BR 306: Trim made of RG/MS (CuZn35Ni3Mn2AlPb, CW710R code number 02 CuSn10-Cu, CC480K code number 03)			
Test:	34.006 DN 15-400	TÜ.A/TÜV.AR 187-00	
	35.006 DN 15-200	TÜ.A/TÜV.AR 187-00	
	DN 15-300 optional:	German "TA-Luft" TÜV-Test-No. 922-9204866 (refer to page 14)	

Selection of possible applications:

- Industry
- Powerstations
- Flue gas purification plant
- Vapour facilities
- Recycling facilities
- Shipbuilding
- General plant manufacturing

- other applications on request -

Weights (kg)

Figure-No.	DN	15	20	25	32	40	50	65	80	100	125	150	200	250	300	350	400	500
34.006 / 34.306		4,4	5,4	6,3	7,0	10,5	13,8	21,0	27,5	40,0	61,0	84,0	160,0	265,0	377,0	510,0	780,0	1095,0
35.006 / 35.306		4,8	5,4	7,1	8,0	11,5	13,5	23,5	28,0	39,5	61,0	84,0	170,0	283,0	414,0	557,0	857,0	1150,0

ARI-STOBU® - Stop valve with gland seal, made of forged steel

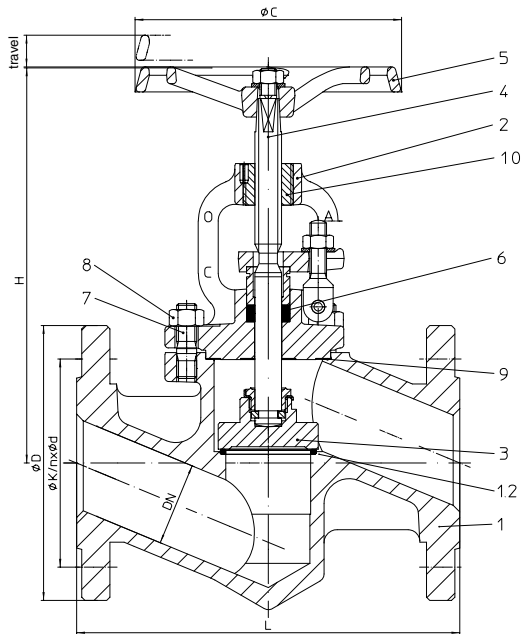

Figure	Nominal pressure	Material	Nominal diameters
45.006	PN 40	C22.8	DN 15-50
for DN >50 refer to Fig. 35.006 (1.0619+N)			
Test: TÜ.A/TÜV.AR 187-00 optional: German "TA-Luft" TÜV-Test-No. 922-9204866 (refer to page 14)			

Selection of possible applications:

- Industry
- Powerstations
- Flue gas purification plant
- Vapour facilities
- Recycling facilities
- Shipbuilding
- General plant manufacturing

- other applications on request -

Weights (kg)

Figure-No.	DN	15	20	25	32	40	50	65	80	100	125	150	200	250	300	350	400	500
45.006		4,3	5,0	6,0	7,0	10,0	13,0	--	--	--	--	--	--	--	--	--	--	--

ARI-STOBU® - Stop valve with gland seal, made of stainless steel

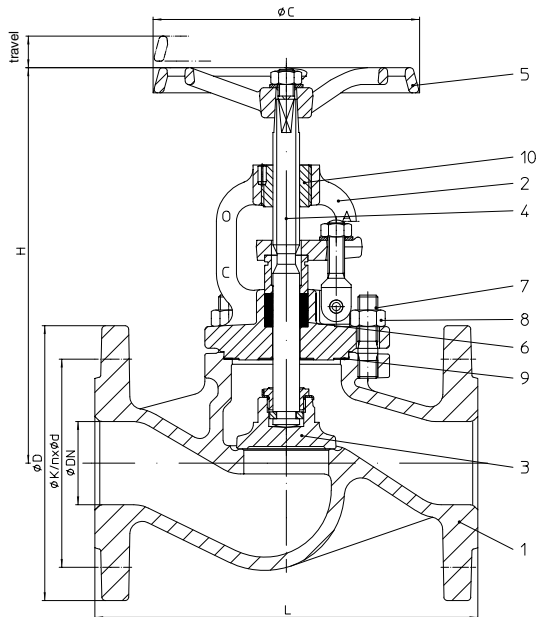

Figure	Nominal pressure	Material	Nominal diameters
52.006	PN 16	1.4408	DN 15-200
54.006	PN 25	1.4408	DN 200
55.006	PN 40	1.4408	DN 15-150
Test: optional: German "TA-Luft" TÜV-Test-No. 922-9204866 (refer to page 14)			

Selection of possible applications:

- Recycling facilities
- Chemical industry
- Hospital technology
- Processing technology
- Process water installations
- Installations with aggressive media

- other applications on request -

Weights (kg)

Figure-No.	DN	15	20	25	32	40	50	65	80	100	125	150	200	250	300	350	400	500
52.006 / 54.006 / 55.006		4,8	5,4	7,1	8,0	11,5	13,5	23,5	28,0	39,5	61,0	84,0	170,0	--	--	--	--	--

ARI-STOBU® - Stop valve with gland seal, made of forged steel

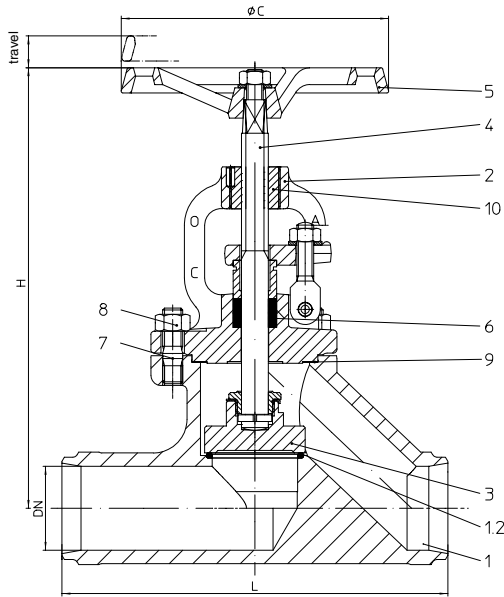

Figure	Nominal pressure	Material	Nominal diameters
45.005	PN 40	C22.8	DN 15-50
for DN >50 refer to Fig. 35.005 (1.0619+N)			
Butt weld ends according to DIN EN 12627-4 (refer to page 7)			
Test: TÜ.A/TÜV.AR 187-00 optional: German "TA-Luft" TÜV-Test-No. 922-9204866 (refer to page 14)			

Selection of possible applications:

- Industry
- Powerstations
- Flue gas purification plant
- Vapour facilities
- Recycling facilities
- Shipbuilding
- General plant manufacturing

- other applications on request -

Weights (kg)

Figure-No.	DN	15	20	25	32	40	50	65	80	100	125	150	200	250	300	350	400	500
45.005		2,9	3,0	3,5	3,5	6,2	7,8	--	--	--	--	--	--	--	--	--	--	--

ARI-STOBU® - Stop valve with gland seal, made of cast steel

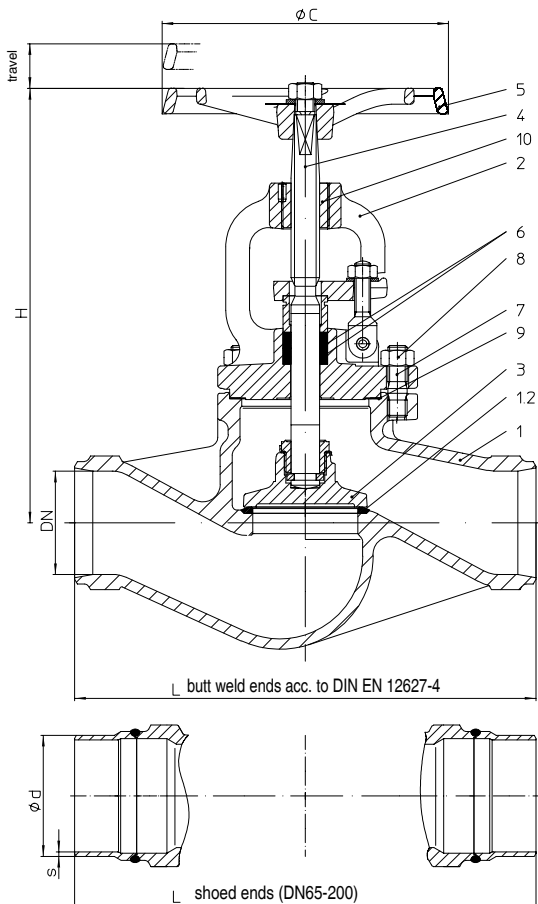

Figure	Nominal pressure	Material	Nominal diameters
35.005	PN 40	1.0619+N	DN 65-300
for DN <65 refer to Fig. 45.005 (C22.8)			
Butt weld ends acc. to DIN EN 12627-4 (ref. to page 7) alternative: DN 65-200 with shoed ends of St 35.8			
Test: TÜ.A/TÜV.AR 187-00 optional: German "TA-Luft" TÜV-Test-No. 922-9204866 (refer to page 14)			

Selection of possible applications:

- Industry
- Powerstations
- Flue gas purification plant
- Vapour facilities
- Recycling facilities
- Shipbuilding
- General plant manufacturing

- other applications on request -

Weights (kg)

Figure-No.	DN	65	80	100	125	150	200	250	300
35.005		16,0	21,0	28,0	45,0	66,0	143,0	228,0	345,0

ARI-STOBU® - Stop valve with gland seal, made of stainless steel

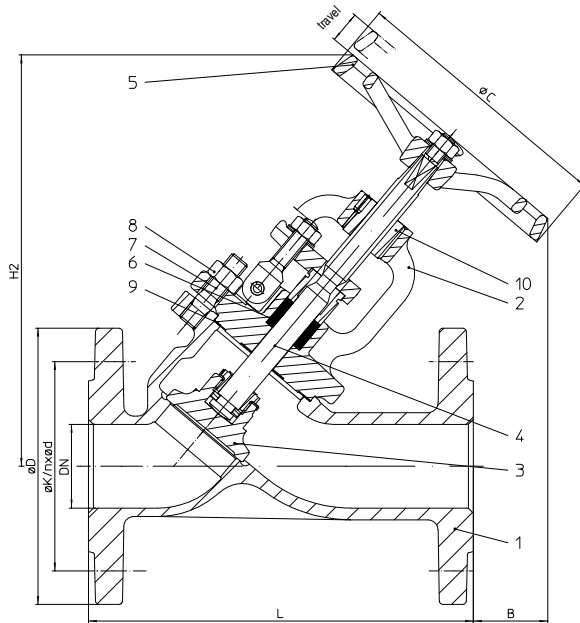

Figure	Nominal pressure	Material	Nominal diameters
52.009	PN 16	1.4408	DN 15-200
54.009	PN 25	1.4408	DN 15-200
55.009	PN 40	1.4408	DN 15-200
Test:	optional: German "TA-Luft" TÜV-Test-No. 922-9204866 (refer to page 14)		

Selection of possible applications:

- Recycling facilities
- Chemical industry
- Hospital technology
- Processing technology
- Process water installations
- Installations with aggressive media

- other applications on request -

Weights (kg)

Figure-No.	DN	15	20	25	32	40	50	65	80	100	125	150	200	250	300	350	400	500
52.009 / 54.009 / 55.009		4,0	4,6	6,0	7,6	9,4	11,6	16,5	23,2	35,0	43,0	72,0	141,0	--	--	--	--	--

ARI-STOBU® - Stop valve with gland seal, made of cast iron and nodular iron

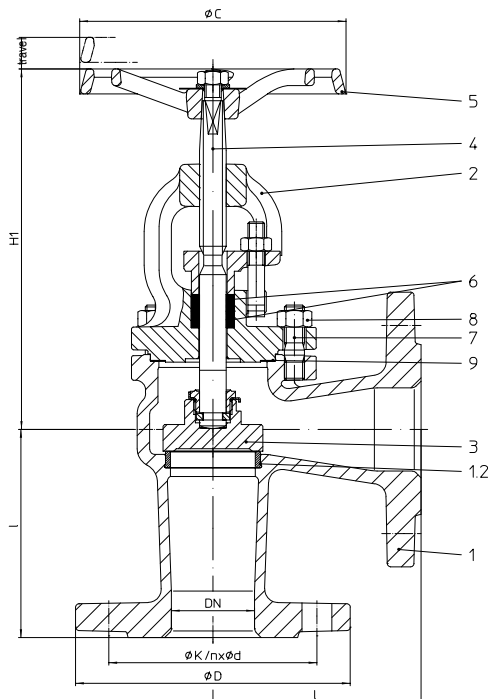

Figure	Nominal pressure	Material	Nominal diameters
12.007	PN 16	GG-25	DN 15-300
12.307			
22.007	PN 16	GGG-40.3	DN 15-500
22.307			
BR 307: Trim made of RG/MS (CuZn35Ni3Mn2AlPb, CW710R code number 02 CuSn10-Cu, CC480K code number 03)			
Test:	DN 15-300 optional: German "TA-Luft" TÜV-Test-No. 922-9204866 (refer to page 14)		

Selection of possible applications:

- Industry
- Powerstations
- Flue gas purification plant
- Vapour facilities
- Recycling facilities
- Shipbuilding
- General plant manufacturing

- other applications on request -

Weights (kg)

Figure-No.	DN	15	20	25	32	40	50	65	80	100	125	150	200	250	300	350	400	500
12.007 / 12.307		3,9	4,5	5,5	6,6	9,1	11,5	17,1	22,4	32,0	46,0	67,0	126,0	184,0	270,0	--	--	--
22.007 / 22.307		4,0	4,5	5,6	6,6	9,2	11,6	17,0	22,6	33,0	46,0	68,0	100,0	204,0	270,0	398,0	570,0	885,0

ARI-STOBU® - Stop valve with gland seal, made of cast steel

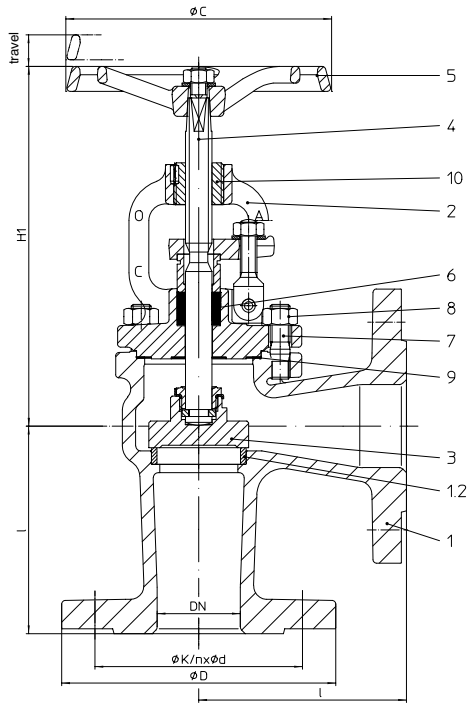

Figure	Nominal pressure	Material	Nominal diameters
34.007	PN 25	1.0619+N	DN 15-500
34.307			
35.007	PN 40	1.0619+N	DN 15-500
35.307			
BR 307: Trim made of RG/MS (CuZn35Ni3Mn2AlPb, CW710R code number 02 CuSn10-Cu, CC480K code number 03)			
Test:	34.007 DN 15-400	TÜ.A/TÜV.AR 187-00	
	35.007 DN 15-150	TÜ.A/TÜV.AR 187-00	
	DN 15-300 optional:	German "TA-Luft" TÜV-Test-No. 922-9204866 (refer to page 14)	

Selection of possible applications:

- Industry
- Powerstations
- Flue gas purification plant
- Vapour facilities
- Recycling facilities
- Shipbuilding
- General plant manufacturing

- other applications on request -

Weights (kg)

Figure-No.	DN	15	20	25	32	40	50	65	80	100	125	150	200	250	300	350	400	500
34.007 / 34.307		5,2	7,2	7,4	8,4	12,4	13,6	20,0	25,0	34,0	53,0	70,0	138,0	170,0	290,0	383,0	690,0	963,0
35.007 / 35.307		5,2	7,2	7,4	8,4	12,4	13,6	20,0	25,0	34,0	53,0	70,0	148,0	188,0	327,0	430,0	767,0	1018,0

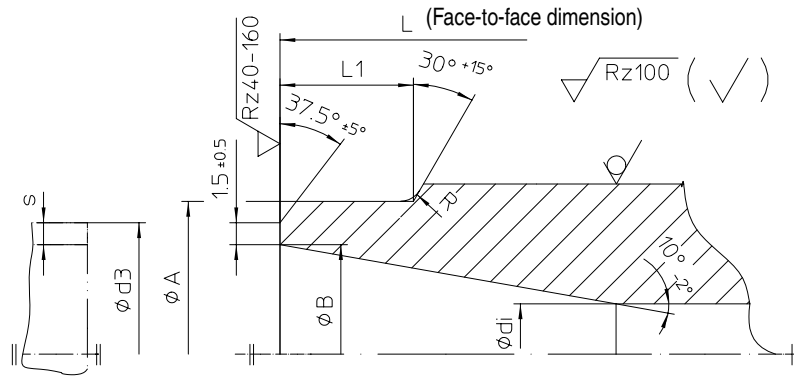

Edge shaping according to DIN EN 25817

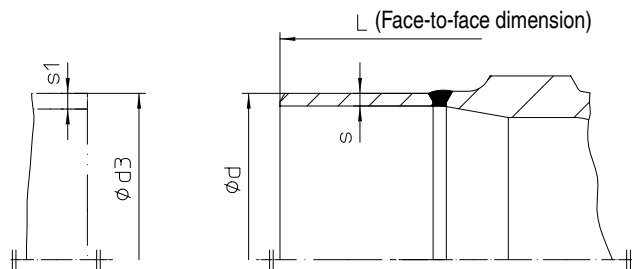

DN	L	Butt weld ends according to DIN EN 12627-4						Shoed ends made of P235GH Pipe connection ≙ welding neck flanges	
		ϕA	ϕB	ϕdi	ϕR	L1	Pipe $\phi D3 \times s1$	ϕd	s
15	130	22	17,3	15	3	10	21,3 x 2,0	--	--
20	150	28	22,3	20	3	10	26,9 x 2,3	--	--
25	160	35	28,5	25	3	10	33,7 x 2,6	--	--
32	180	44	37,2	32	3	10	42,4 x 2,6	--	--
40	200	50	43,1	40	3	10	48,3 x 2,6	--	--
50	230	62	53,9	50	3	10	60,3 x 3,2	--	--
65	290	77	68,9	65	3	10	76,1 x 2,9	76,1	2,9
80	310	91	80,9	80	3	12	88,9 x 4,0	88,9	4,0
100	350	117	104,3	100	3	14	114,3 x 5,0	114,3	5,0
125	400	144	130,7	125	3	18	139,7 x 4,5	139,7	4,5
150	480	172	157,1	150	3	20	168,3 x 5,6	168,3	5,6
200	600	223	204,9	200	5	20	219,1 x 7,1	219,1	7,1
250	730	278	257,0	250	5	25	273,0 x 8,0	--	--
300	850	329	307,9	300	5	33	323,9 x 8,0	--	--
350	980	362	338,0	330	5	45	355,6 x 8,8	--	--
400	1100	413	384,4	375	5	45	406,4 x 11,0	--	--

Face-to-face dimension according to DIN EN 12982 ETE-1 (DIN 3202 T2)

Butt weld ends according to DIN EN 12627-4 (DIN 3239 T1, form 2)

Weld joint according to DIN EN 29692 code number 1.3.3 (DIN 2559 T1, code number 22)

The material used for ARI valves with butt weld ends is: 1.0619+N (GS-C25N) according to DIN EN 10213-1-2, C22.8 according to DIN 17243.

The material used for ARI valves with shoed ends (DN 65-200) P235GH according to DIN EN 10216-2.

Based on our experience we recommend electric welding process for connecting valves or strainers with tubes or with each other.

Lime based electrodes with an appropriate composite material should be used as filler material for welding.

Gas welding should be avoided.

Due to the different material composition and material thickness of valves and tubes, gas welding is more susceptible to produce faults than electric welding (hardness cracks, coarse-grained structure).

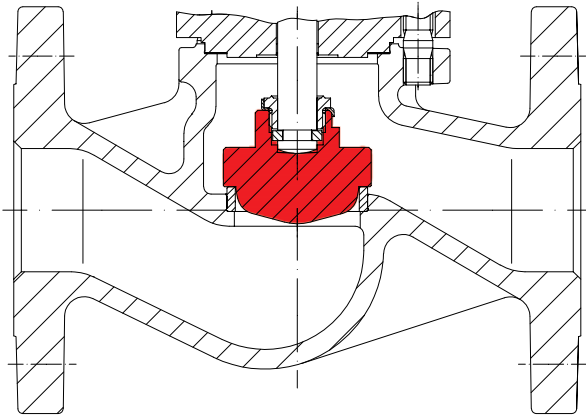

Regulating plug

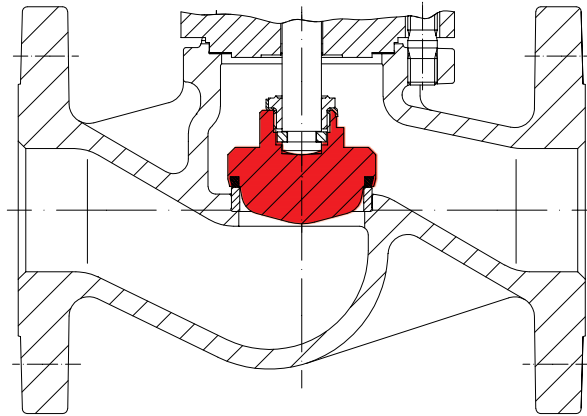

Regulating plug with soft seal, PTFE + 25% carbon
Max. operating temperature 200 °C

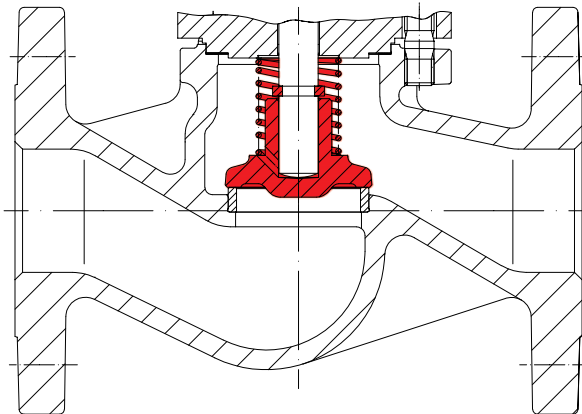

Screw down non-return plug with re-setting spring - max differential pressure, refer to table of pressure balancing plugs (page 9)
Set pressure 0,1 bar
(Design for special applications refer to page 10)

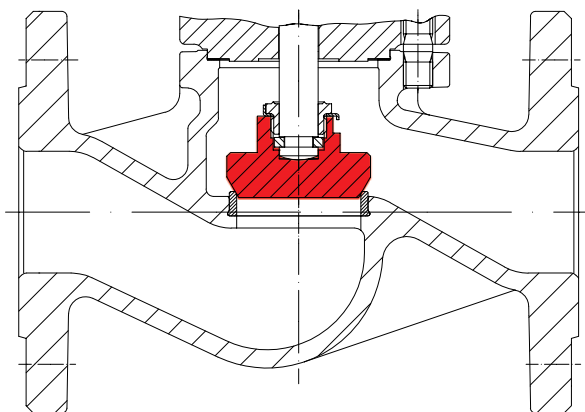

Plug with marginal seat

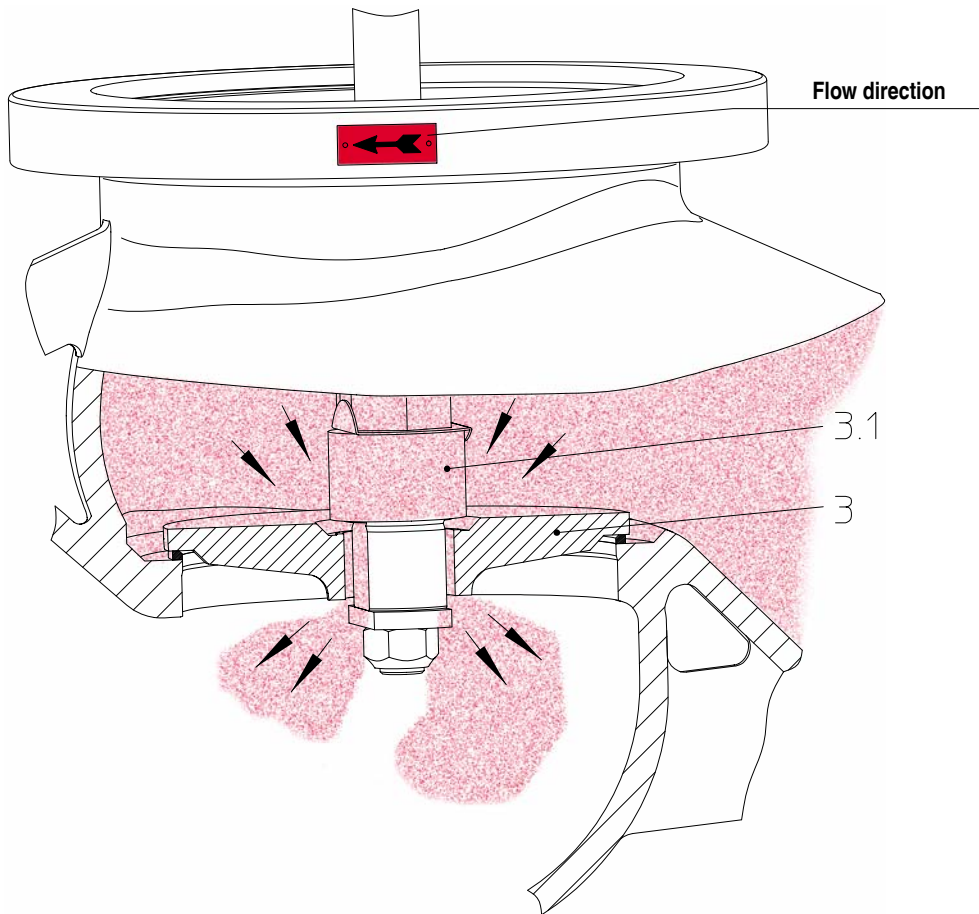

Valves with **balancing plugs** have to be installed with medium flowing over the plug (3) as indicated by flow direction arrow on valve body.

Working principles:

When the valve is closed, anticlockwise rotation of the hand wheel lifts the pilot plug (3.1) off the larger balancing plug (3). This allows the medium to pass through the plug and equalizes the pressure of the medium under the plug (3). After the pressures have been equalized within the valves stated in the table, the valve can be opened by turning the valve further with normal manual force.

Balancing plugs are fully effective only in closed systems.

The pressures of the medium on either side of the plug cannot be equalized if the medium is discharged into "open air".

A bypass line or some other arrangement is necessary if too much time is required for pressure equalization owing to the volume in the piping system.

ARI-stop valves with differential pressures exceeding the following pressures, have to be fitted with pressure balancing plugs:

Balancing plug	DN	125	150	200	250	300	350	400	500
Differential pressure	D p	25 bar	21 bar	14 bar	9 bar	6 bar	4,5 bar	3,5 bar	1,5 bar

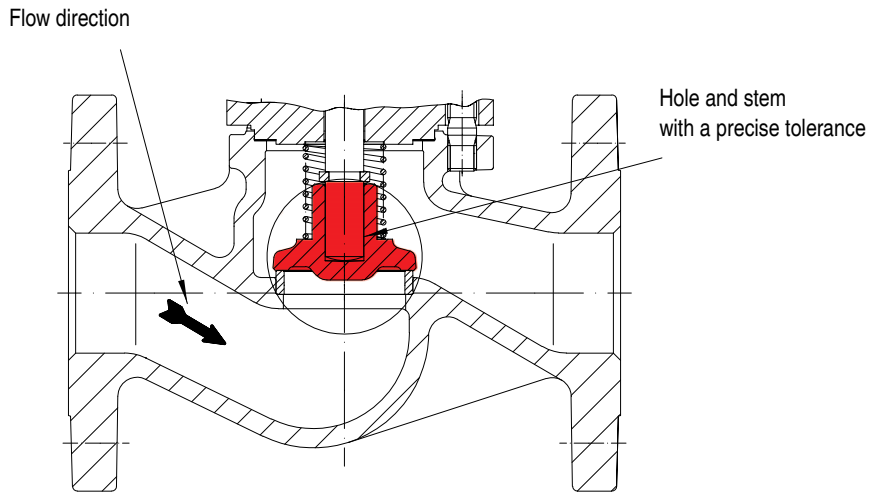

Screw down non-return plug with re-setting spring and plug damper

In special applications, like high flow turbulences, stuffing box valves with damper should be used with execution „screw down non-return plug“:

- if stuffing box valves with loose plug are mounted directly by centrifuged pumps;
- behind pressure reduction stations;
- behind pipe elbows;
- in compact plants;
- if expansion joints are missing;
- if the pump is not mounted on a damper;
- if there is no flow stabilizing pipe dimension;
- if there is no start-up bypass line;
- when chosen valve diameter to large.

Working principle

The precise tolerance between stem and plug hole prevents an abrupt displacement of medium out of the plug.

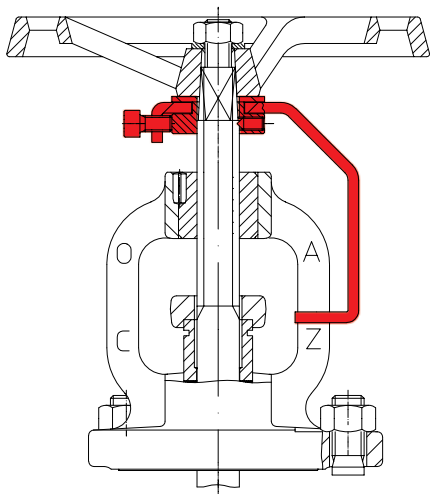

Position indicator with locking device

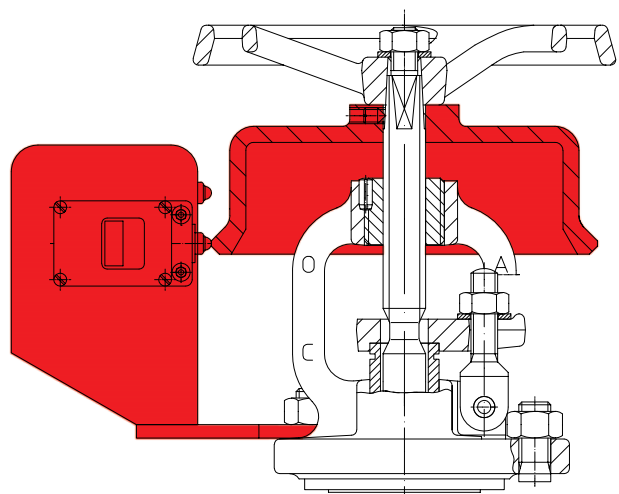

Limit switches

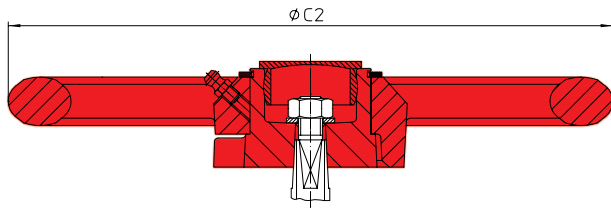

DN	$\varnothing C2$ (mm)	Weight (kg)
15- 32	180	1,5
40- 100	250	3,0
125-200	365	5,0
250-500	520	13,0

Handwheel operated by impact force

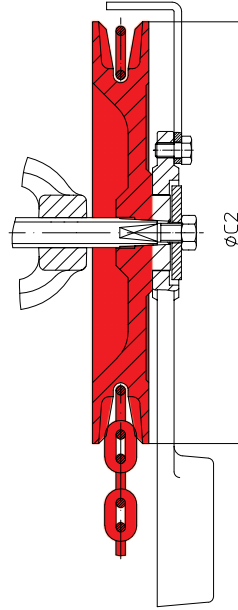

DN	$\varnothing C2$ (mm)	Weight (kg)
15- 32	180	2,5
40- 80	220	7
100-125	260	8,9
150-400	300	11

Chain wheel

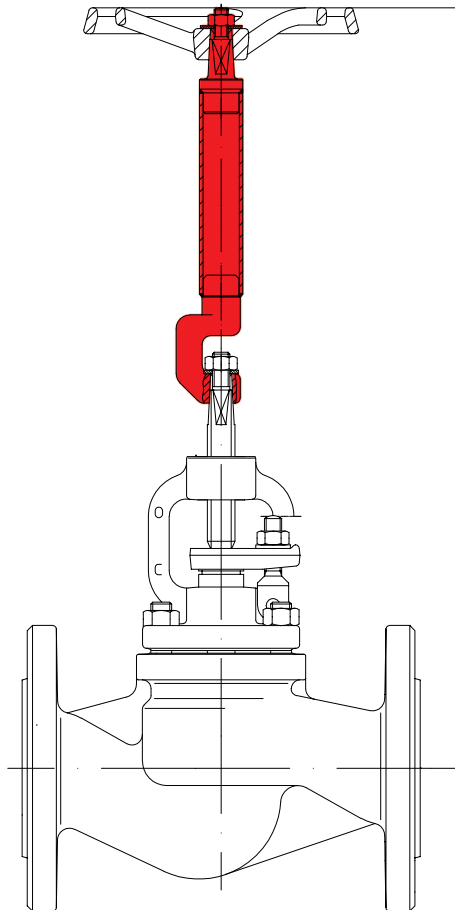

Stem extension (please specify the height in your order)

Dimensions, kvs- and zeta-values

DN	L	I	B	H	H1	H2	Travel	ØC	Kvs-values				Zeta-values			
									straight through	forged bodies	Y-pattern	Angle-pattern	straight through	forged bodies	Y-pattern	Angle-pattern
15	130	90	80	185	185	200	9	120	4,2	3,3	5,8	5,2	4,4	7,2	2,3	2,8
20	150	95	70	185	185	200	9	120	7,4	5,8	8,6	9,2	4,5	7,3	3,3	2,9
25	160	100	85	205	200	225	13	140	12	9,2	13,0	15,0	4,4	7,1	3,4	2,8
32	180	105	70	205	200	225	13	140	19	15,0	20,0	24,0	4,2	7,2	3,9	2,7
40	200	115	70	230	215	245	21	160	31	23,3	42,0	37,0	4,1	7,3	2,2	2,9
50	230	125	45	230	215	250	19	160	47	36,0	59,0	58,0	4,4	7,4	2,7	2,8
65	290	145	30	270	245	285	28	180	77	--	90,0	96,0	4,6	--	3,4	2,9
80	310	155	65	305	280	320	32	200	120	--	127,0	150,0	4,3	--	3,9	2,8
100	350	175	75	355	320	415	36	225	188	--	205,0	235,0	4,3	--	3,6	2,7
125	400	200	80	395	360	435	52	250	288	--	310,0	360,0	4,5	--	3,9	2,9
150	480	225	75	450	415	505	56	400	410	--	445,0	510,0	4,6	--	3,9	3,0
200	600	275	130	570	495	640	73	520	725	--	800,0	905,0	4,6	--	3,8	3,0
250	730	325	--	685	575	--	80	520	1145	--	--	1430,0	4,5	--	--	2,9
300	850	375	--	770	655	--	110	520	1635	--	--	2040,0	4,6	--	--	3,0
350	980	425	--	860	735	--	116	640	2220	--	--	2775,0	4,6	--	--	3,0
400	1100	475	--	865	740	--	126	640	3180	--	--	3975,0	3,9	--	--	2,5
500	1350 ¹⁾	525 ¹⁾	--	995	840	--	181	640	4530	--	--	5660,0	4,6	--	--	3,0

Zeta-value ... range of tolerance for Kvs-values acc. to DIN EN 60534.

¹⁾ Face-to-face dimension/leg dimension acc. to ARI-works standard

Dimensions of flanges refer to page 13 or the ARI quick reference slide chart (available on request).

Globe valves with flanges:
Face-to-face dimension FTF series 1 according to DIN EN 558-1 (DIN 3202-1 series F1)
Y-pattern globe valves with flanges:
Face-to-face dimension FTF series 1 according to DIN EN 558-1 (DIN 3202-1 series F1)
Angle pattern globe valves with flanges:
Face-to-face dimension CTF series 8 according to DIN EN 558-1 (DIN 3202-1 series F32)
Globe valves with butt weld ends:
Face-to-face dimension ETE series 1 according to DIN EN 12982 (DIN 3202-2 series S7)

Figure	12.006 12.007	22/23.006 22/23.007	34/35.006 34/35.007	35.005 35.007	12.306/307	22/23.306 22/23.307	34/35.306; 34/35.307	45.005 45.006	52./54./55.006 52./54./55.009	
Pos.	Description									
Material, Material-No.										
1	Body	GG-25, 0.6025	GGG-40.3, 0.7043	1.0619+N, 1.0619.01	GG-25, 0.6025	GGG-40.3, 0.7043	1.0619+N, 1.0619.01	C22.8, 1.0460	GX5CrNiMo19- 11-2, 1.4408	
1.2	Seat	X20Cr13+QT, 1.4021+QT		DN≤50: X20Cr13+ QT, 1.4021+QT; DN>50: 1.4551	CuSn10-Cu, CC480K code number 03 ²⁾			G19 9 Nb Si, 1.4551	--	
2	Bonnet	GG-25, 0.6025	GGG-40.3, 0.7043	DN ≤ 80: C22.8, 1.0460 DN > 80: 1.0619+N, 1.0619.01	GG-25, 0.6025	GGG-40.3, 0.7043	DN ≤ 80: C22.8, 1.0460 DN > 80: 1.0619+N, 1.0619.01	C22.8, 1.0460	DN ≤ 80: X2CrNiMo17- 12-2, 1.4404 DN > 80: GX5CrNiMo19- 11-2, 1.4408	
3	Plug	DN ≤ 200: X20Cr13+QT, 1.4021+QT DN > 200: P265 GH, 1.0425 / G17			CuZn35Ni3Mn2AlPb, CW710R code number 02 ²⁾ CuSn10-Cu, CC480K code number 03 ²⁾			X20Cr13+QT, 1.4021+QT	X6CrNiMoTi17- 12-2, 1.4571	
4	Stem	X20Cr13+QT, 1.4021+QT burnished			CuSn8, CW453K code number 03 ²⁾ burnished			X20Cr13+QT, 1.4021+QT burnished	X6CrNiMoTi17- 12-2, 1.4571	
5	Handwheel	GG-25, 0.6025 coated								
6	Gland packing	Pure graphite								
7	Hexagon screws Studs	5.6	25CrMo4, 1.7218			5.6	25CrMo4, 1.7218			A 4-70
8	Hexagon nuts	C35E, 1.1181			C35E, 1.1181			A4		
9	Gasket	CrNi laminated both sides with pure graphite								
10	Threaded bushing	--	--	11SMnPb30+C, 1.0718+C	--	--	11SMnPb30+C, 1.0718+C		X5CrNiMo17- 12-2, 1.4401	

²⁾ max. operating temperature: 225 °C (code number acc. to DIN 86251)

Informations / restrictions of technical rules have to be observed!

Operating instructions can be ordered on request by phone (+49 52 07) 994-0 or fax (+49 52 07) 994-158 or 159.

ARI-valves made of GG-25 are not allowed to be operated in systems according to TRD 110.

A production allowance according to TRB 801 No. 45 exists (according to TRB801 No. 45 GG-25 is not allowed).

The engineer, designing a system or a plant, is responsible for the selection of the correct valve.

ARI-STOBU flow diagrams refer to technical annex
Leakage rate according to DIN 3230-3 (leakage rate 1)
Alternative description according to DIN 3356 „valves“
Pressure-temperature-ratings

Flangeholes-/thickness tolerances acc. to DIN 2533 / DIN 2544 / DIN 2545

acc. to DIN EN 1092-2		Temperature								
Material	PN	-60°C up to <-10°C*	-10°C up to 120°C	150°C	200°C	250°C	300°C	350°C	400°C	450°C
GG-25	16	---	16 bar	14,4 bar	12,8 bar	11,2 bar	9,6 bar	---	---	---
GGG-40.3	16	on request	16 bar	15,5 bar	14,7 bar	13,9 bar	12,8 bar	11,2 bar	---	---
	25	on request	25 bar	24,3 bar	23 bar	21,8 bar	20 bar	17,5 bar	---	---

acc. to DIN EN 1092-1		Temperature									
Material	PN	-60°C up to <-10°C*	-10°C up to 50°C	100°C	150°C	200°C	250°C	300°C	350°C	400°C	450°C
1.0619+N	25	18,7 bar	25 bar	23,3 bar	21,7 bar	19,4 bar	17,8 bar	16,1 bar	15 bar	14,4 bar	13,9 bar
	40	30 bar	40 bar	37,3 bar	34,7 bar	30,2 bar	28,4 bar	25,8 bar	24 bar	23,1 bar	22,2 bar
C22.8	25	18,7 bar	25 bar	23,3 bar	21,7 bar	19,4 bar	17,8 bar	16,1 bar	15 bar	14,4 bar	10 bar
	40	30 bar	40 bar	37,3 bar	34,7 bar	30,2 bar	28,4 bar	25,8 bar	24 bar	23,1 bar	16 bar
1.4408	16	16 bar	16 bar	14,9 bar	13,5 bar	12,4 bar	11,7 bar	11 bar	10,7 bar	10,2 bar	---
	25	25 bar	25 bar	23,3 bar	21,1 bar	19,4 bar	18,3 bar	17,2 bar	16,7 bar	16 bar	---
	40	40 bar	40 bar	37,3 bar	33,8 bar	31,1 bar	29,3 bar	27,6 bar	26,7 bar	25,6 bar	---

Intermediate values for max. permissible operational pressures can be determined by linear interpolation of the given temperature / pressure chart.

* Studs and nuts made of A4-70 (at temperatures below -10°C)

Flange dimensions

DN	PN 6			PN 16			PN 25			PN 40		
	∅ D	∅ K	n x ∅ d1	∅ D	∅ K	n x ∅ d1	∅ D	∅ K	n x ∅ d1	∅ D	∅ K	n x ∅ d1
15	80	55	4 x 11	95	65	4 x 14	95	65	4 x 14	95	65	4 x 14
20	90	65	4 x 11	105	75	4 x 14	105	75	4 x 14	105	75	4 x 14
25	100	75	4 x 11	115	85	4 x 14	115	85	4 x 14	115	85	4 x 14
32	120	90	4 x 14	140	100	4 x 18	140	100	4 x 18	140	100	4 x 18
40	130	100	4 x 14	150	110	4 x 18	150	110	4 x 18	150	110	4 x 18
50	140	110	4 x 14	165	125	4 x 18	165	125	4 x 18	165	125	4 x 18
65	160	130	4 x 14	185	145	4 x 18	185	145	8 x 18	185	145	8 x 18
80	190	150	4 x 18	200	160	8 x 18	200	160	8 x 18	200	160	8 x 18
100	210	170	4 x 18	220	180	8 x 18	235	190	8 x 22	235	190	8 x 22
125	240	200	8 x 18	250	210	8 x 18	270	220	8 x 26	270	220	8 x 26
150	265	225	8 x 18	285	240	8 x 22	300	250	8 x 26	300	250	8 x 26
200	320	280	8 x 18	340	295	12 x 22	360	310	12 x 26	375	320	12 x 30
250	---	---	---	405	355	12 x 26	425	370	12 x 30	450	385	12 x 33
300	---	---	---	460	410	12 x 26	485	430	16 x 30	515	450	16 x 33
350	---	---	---	520	470	16 x 26	555	490	16 x 33	580	510	16 x 36
400	---	---	---	580	525	16 x 30	620	550	16 x 36	660	585	16 x 39
500	---	---	---	715	650	20 x 33	730	660	20 x 36	755	670	20 x 42

Butt weld ends according to DIN EN 12627-4 (refer to page 7)
Please indicate when ordering:

- Figure-No.
- Nominal pressure
- Nominal diameter
- Special design / accessories

Example:

Figure 35.006; nominal pressure PN40; nominal diameter DN100; with throttling plug, position indicator with locking device.

Dimensions in mm
Weights in kg
1 bar $\hat{=}$ 10 ⁵ Pa $\hat{=}$ 0,1 MPa
Kvs in m ³ /h
1Kvs $\hat{=}$ 1,16 Cv (US)

ARI-STOBU® - Testing German „TA-Luft“ optional at DN 15 - 300 (TÜV-Test-No. 922-9204866)

with **not spring-loaded** stuffing box

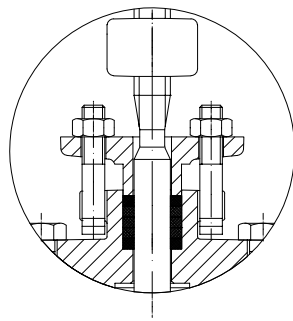

Cast iron and nodular iron

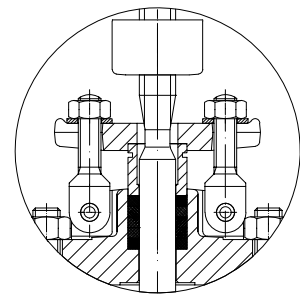

Cast steel, forged steel and stainless steel

with **spring-loaded** stuffing box

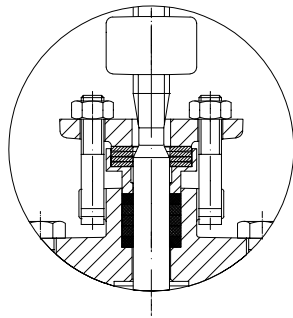

Cast iron and nodular iron

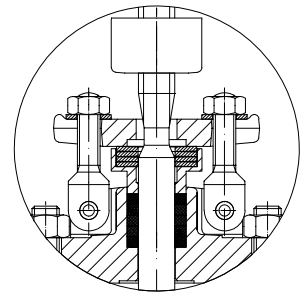

Cast steel, forged steel and stainless steel



Technology for the Future.
GERMAN QUALITY VALVES