

DESIGN FEATURES

- Built-in ISO 5211 Direct Mounting Pad Easy Automation
- Anti-static Devices for Ball-Stem-Body
- Blow-out Proof Stem
- ISO 15848-1 Design Approved (Optional)
- NACE MR-0175 (Optional)
- Casting Approved by TUV AD 2000-Merkblatt W0
- Options : 1.Actuor 2.Limit 3.Positioner

APPLICABLE STANDARDS

- Design Standard : MSS SP-110
- Clamp Ends : KV-L9C/A ASME BPE
KV-L9C/B BS4825
KV-L9C/I ISO2852
KV-L9C/D DIN 32676
- Butt Weld Ends : KV-L91/A ASME BPE
KV-L91/B BS4825&BPE
KV-L91/I ISO 2037
KV-L91/D DIN 11850
- Inspection & Testing : MSS SP-110



TECHNICAL INFORMATION

SIZE		CV	Weight					
NPS	DN		KV-L9C/A, B		KV-L9C/I		KV-L9C/D	
			(kg)	(lb)	(kg)	(lb)	(kg)	(lb)
1/2	15	18	0.69	1.53	0.58	1.28	0.58	1.28
3/4	20	36	0.95	2.08	1.03	2.27	1.03	2.27
1	25	48	1.46	3.22	1.44	3.17	1.44	3.17
1 1/4	32	93	—	—	1.95	4.30	1.95	4.30
1 1/2	40	165	2.89	6.37	2.96	6.53	2.96	6.53
2	50	207	4.35	9.59	4.48	9.89	4.50	9.92
2 1/2	65	450	8.20	18.08	8.70	19.18	8.38	18.47
3	80	780	11.60	25.57	11.60	25.57	11.85	26.12
4	100	1360	22.6	49.82	23.30	51.37	23.30	51.37

SIZE		CV	Weight					
NPS	DN		KV-L91/A, B		KV-L91/I		KV-L91/D	
			(kg)	(lb)	(kg)	(lb)	(kg)	(lb)
1/2	15	18	0.65	1.43	0.65	1.43		
3/4	20	36	0.92	2.02	0.87	1.92		
1	25	48	1.31	2.90	1.50	3.31		
1 1/4	32	93	—	—	1.92	4.23		
1 1/2	40	165	2.84	6.25	2.94	6.48		
2	50	207	4.25	9.37	4.48	9.87		
2 1/2	65	450	7.90	17.42	8.70	19.18		
3	80	780	11.35	25.02	12.0	26.46		
4	100	1360	22.0	48.50	23.3	51.37		

TORQUE VALUES

Close to Open Torque at Various Differential Pressure (ΔP), Standard Seats (TFM1600 & PTFE)

unit : in-lb / N-m

Size/ ΔP		75 psig		150 psig		300 psig		400 psig	
		5 bar		10 bar		20 bar		25bar	
NPS	DN	N-m	In-lb	N-m	In-lb	N-m	In-lb	N-m	In-lb
1/2	15	5	44	5	44	5	44	5	44
3/4	20	6	53	6	53	6	53	6	53
1	25	10	88	10	88	11	97	11	97
1 1/4	32	13	115	13	115	15	133	17	150
1 1/2	40	19	168	19	168	22	195	24	212
2	50	25	221	29	257	32	283	34	301
2 1/2	65	40	354	45	398	49	434	52	460
3	80	65	575	72	637	81	717	88	779
4	100	100	885	110	973	122	1080	132	1168

- Remark :
1. Torques will increase about 30% if seat materials are Reinforced Fiber-Glass PTFE
 2. The torque figures at 5 bar pressure are maximum values to be tested after the valves are placed for 24 hours.
 3. For actuator sizing, a safety factor of minimum 30% is recommended.

TECHNICAL INFORMATION

PRESSURE - TEMPERATURE RATINGS

Floating Ball valves, 400PSI
 DN15 ~ DN32
 Full Bore : NPS 1/2 ~ NPS 1 1/4

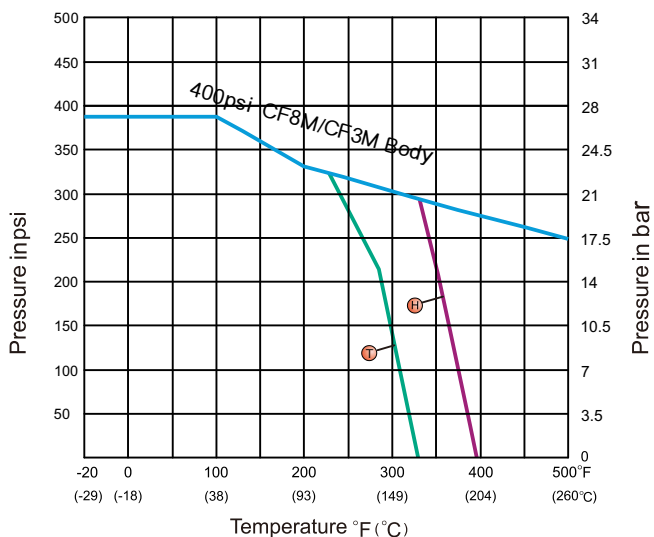

Floating Ball valves, 400PSI
 DN40 ~ DN100
 Full Bore : NPS 1 1/2 ~ NPS 4

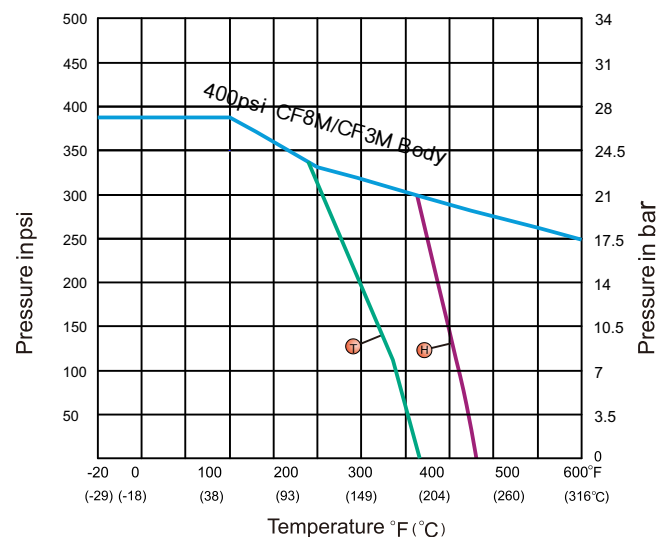

Seat Materials : T PTFE H TFM1600

The pressure-temperature ratings of ball valves are determined, not only by valve shell materials, but also by sealing materials used for ball seats, gland packings, and flange gaskets

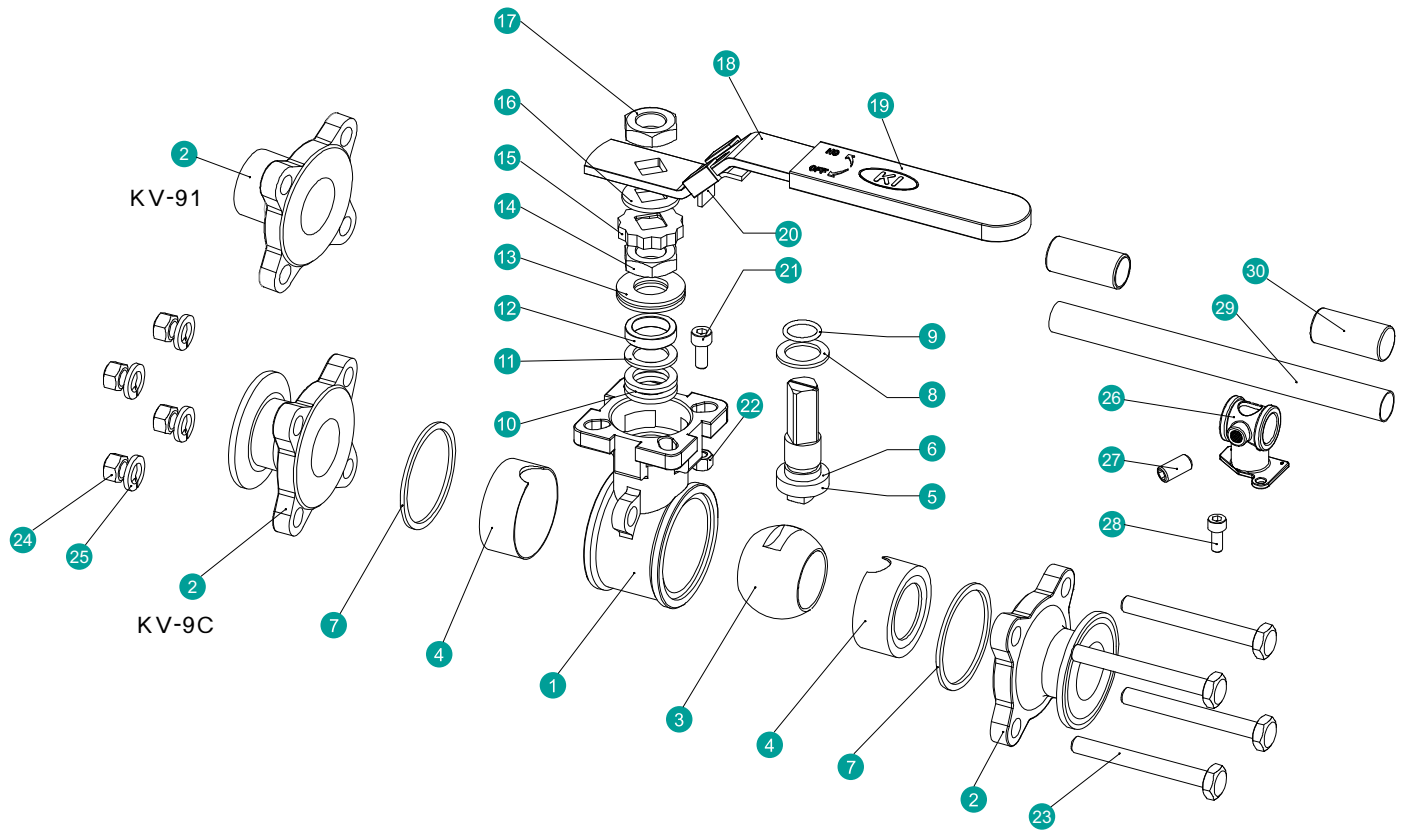

MATERIAL OF CONSTRUCTION

NO.	PART NAME	MATERIALS		
1	Body	CF3M(1.4409)	CF8(1.4408)	WCB(1.4308)
2	End Cap (Clamp)	CF3M(1.4409)	CF8(1.4408)	WCB(1.4308)
	End Cap (BW)	CF3M(1.4409)	CF3(1.4409)	WCB(1.4309)
3	Ball	CF3M	CF8M	CF8
4	Ball Seat	PTFE/TFM1600		
5	Stem	316L	316	304
6	Anti-Static	316L	316	304
7	Body Gasket	PTFE		
8	Thrust washer	PTFE		
9	O-Ring	FKM		
10	Packing	PTFE		
11	Bushing	304		
12	Gland	316		
13	Belleville Washer	301		
14	Stem Nut	A194-8		
15	Stop-lock-Cap	304		
16	Handle Gland	304		
17	Handle Nut (NPS $\frac{1}{2}$ -NPS3)	A194-8		
18	Handle (NPS $\frac{1}{2}$ -NPS3)	304		
19	Handle Sleeve (NPS $\frac{1}{2}$ -NPS3)	VINYL PLASTIC		
20	Lock Device (NPS $\frac{1}{2}$ -NPS3)	304		
21	Stop Bolt	A2-70		
22	Stop Nut	A2-70		
23	Bolting	A193-B8/A2-70		
24	Bolt Nut	A194-8/A2-70		
25	Bolt Washer	304		
26	Handle Adapter (NPS4)	A351-CF8		
27	Set Screwed (NPS4)	A2-70		
28	Bolting (NPS4)	A2-70		
29	Pipe Handle (NPS4)	A53+PLATED Zn		
30	Handle Sleeve (NPS4)	VINYL PLASTIC		

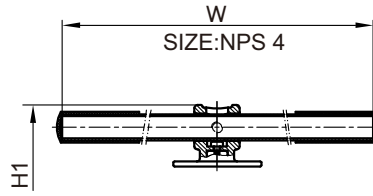
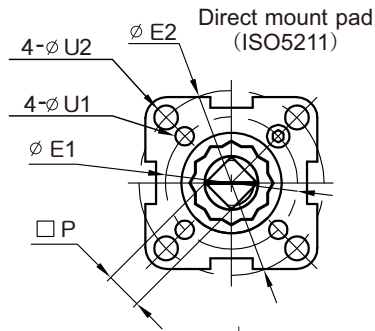

Automation(Optional)

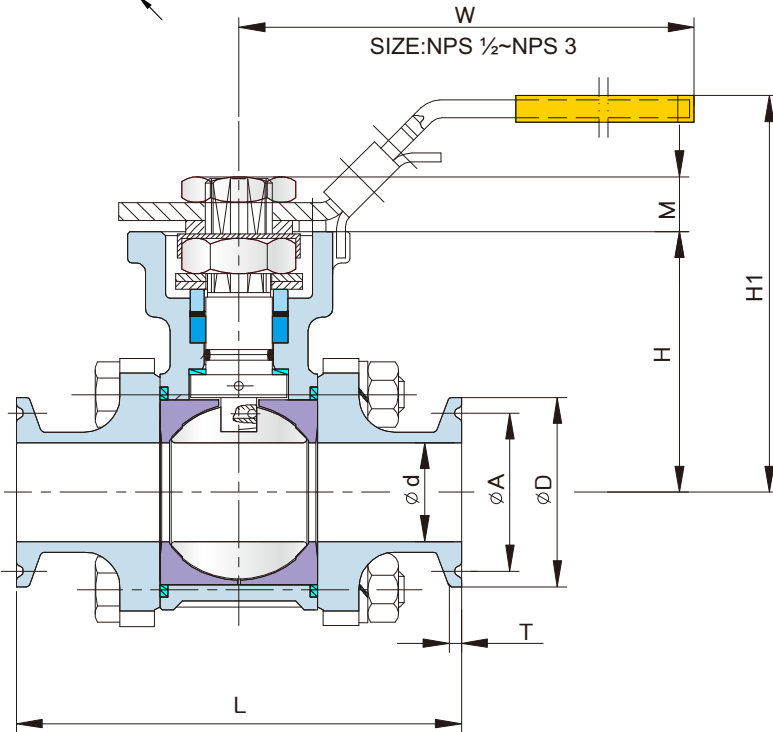
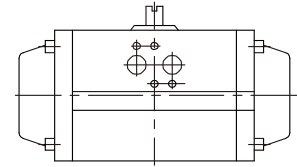

KV-L9C/A End Cap ASME BPE
KV-L9C/B End Cap BS4825

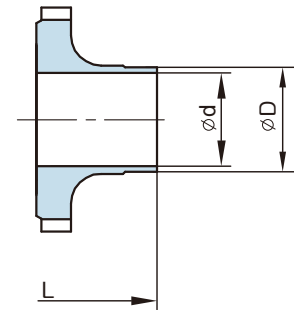

KV-L91/A End Cap ASME BPE
KV-L91/B End Cap BS4825&BPE

DIMENSION TABLE

ANSI 400 WOG DIMENSION TABLE

Unit : mm

SIZE		KV-L9C/A ASME BPE				KV-L9C/B BS4825				L91/A, L91/B		L	H	H1	W	P	M	E1	E2	U1	U2	ISO 5211
NPS	DN	d	A	D	T	d	A	D	T	d	D											
1/2	15	9.4	20.3	25	3.63	9.5	20.3	25.4	3.7	9.5	12.7	90	42	72	147	9	9	36	42	6	6	F03~F04
3/4	20	15.7	20.3	25	3.63	15.9	20.3	25.4	3.7	15.85	19.05	90	49	79	147	9	9	36	50	6	7	F03~F05
1	25	22.2	43.5	50.5	2.85	22.2	43.5	50.5	2.85	22.2	25.4	100	58	90	177	11	11	42	50	6	7	F04~F05
1 1/2	40	34.9	43.5	50.5	2.85	34.9	43.5	50.5	2.85	34.9	38.1	125	71	103	197	14	14	50	70	7	9	F05~F07
2	50	47.6	56.5	64	2.85	47.6	56.5	64	2.85	47.6	50.8	150	78	110	197	14	14	50	70	7	9	F05~F07
2 1/2	65	60.3	70.5	77.5	2.85	60.3	70.5	77.5	2.85	60.3	63.5	190	100	150	267	17	17	70	102	9	11	F07~F10
3	80	73.0	83.5	91	2.85	73.0	83.5	91	2.85	73.0	76.2	220	109	159	267	17	17	70	102	9	11	F07~F10
4	100	97.6	110	119	2.85	97.6	110	119	2.85	97.6	101.6	270	140	212	400	22	22	—	102	—	11	F10

Unit : inch

SIZE		KV-L9C/A ASME BPE				L91/A		L	H	H1	W	P	M	E1	E2	U1	U2	ISO 5211
NPS	DN	d	A	D	T	d	D											
1/2	15	0.37	0.80	0.98	0.14	0.37	0.50	3.54	1.65	2.83	5.79	0.354	0.28	1.42	1.65	0.24	0.24	F03~F04
3/4	20	0.62	0.80	0.98	0.14	0.62	0.75	3.54	1.93	3.11	5.79	0.354	0.35	1.42	1.97	0.24	0.28	F03~F05
1	25	0.87	1.71	1.99	0.11	0.87	1.00	3.94	2.28	3.54	6.97	0.433	0.43	1.65	1.97	0.24	0.28	F04~F05
1 1/2	40	1.37	1.71	1.99	0.11	1.37	1.50	4.92	2.80	4.06	7.76	0.551	0.55	1.97	2.76	0.28	0.35	F05~F07
2	50	1.87	2.22	2.52	0.11	1.87	2.00	5.91	3.07	4.33	7.76	0.551	0.55	1.97	2.76	0.28	0.35	F05~F07
2 1/2	65	2.37	2.78	3.05	0.11	2.37	2.50	7.48	3.94	5.91	10.5	0.669	0.67	2.76	4.02	0.35	0.43	F07~F10
3	80	2.87	3.29	3.58	0.11	2.87	3.00	8.66	4.29	6.26	10.5	0.669	0.67	2.76	4.02	0.35	0.43	F07~F10
4	100	3.84	4.33	4.69	0.11	3.84	4.00	10.63	5.51	8.35	15.9	0.866	0.87	—	4.02	—	0.43	F10

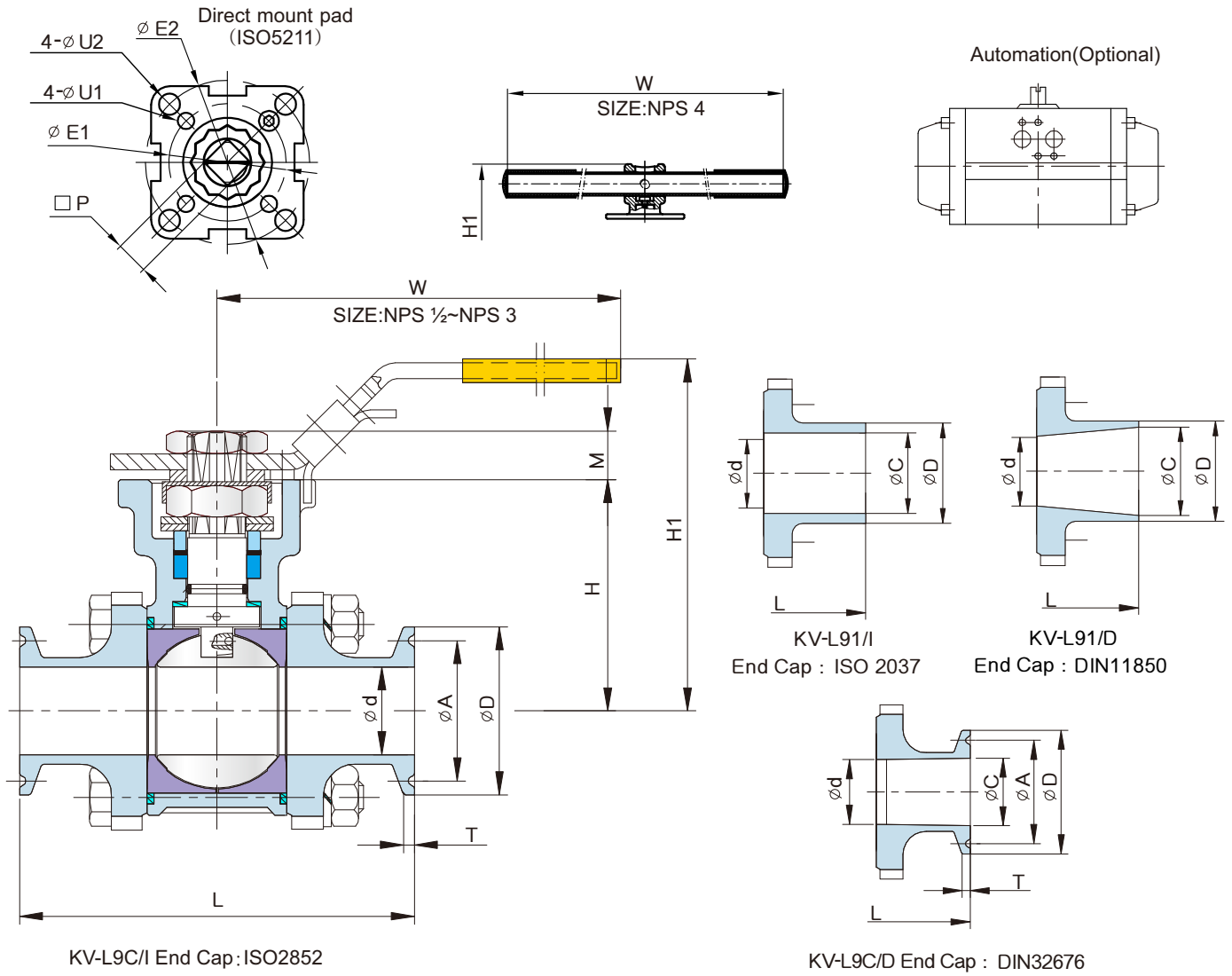

KV-L9C/I End Cap : ISO2852

KV-L9C/D End Cap : DIN32676

DIMENSION TABLE

ANSI 400 WOG DIMENSION TABLE

Unit : mm

SIZE		KV-L9C/I ISO 2852					KV-L91/I ISO 2037			L	H	H1	W	P	M	E1	E2	U1	U2	ISO 5211
NPS	DN	d	A	D	T	d	C	D												
1/2	15	10.7	27.5	34	2.85	10.7	10.7	12.7	90	42	72	147	9	9	36	42	6	6	F03-F04	
3/4	20	15.2	27.5	34	2.85	15.2	15.2	17.2	90	49	79	147	9	9	36	50	6	7	F03-F05	
1	25	22.6	43.5	50.5	2.85	22.6	22.6	25.0	100	58	90	177	11	11	42	50	6	7	F04-F05	
1 1/4	32	31.3	43.5	50.5	2.85	31.3	31.3	33.7	110	63	94	177	11	11	42	70	6	9	F04-F07	
1 1/2	40	35.6	43.5	50.5	2.85	35.6	35.6	38.0	125	71	103	197	14	14	50	70	7	9	F05-F07	
2	50	48.6	56.5	64	2.85	48.6	48.6	51.0	150	78	110	197	14	14	50	70	7	9	F05-F07	
2 1/2	65	60.3	70.5	77.5	2.85	60.3	60.3	63.5	190	100	150	267	17	17	70	102	9	11	F07-F10	
3	80	72.9	83.5	91	2.85	72.9	72.9	76.1	220	109	159	300	17	17	70	102	9	11	F07-F10	
4	100	97.6	110	119	2.85	97.6	97.6	101.6	270	140	212	400	22	22	—	102	—	11	F10	

Unit : mm

SIZE		KV-L9C/D DIN32676					KV-L91/D DIN32676 & DIN11850			L	H	H1	W	P	M	E1	E2	U1	U2	ISO 5211
NPS	DN	d	A	D	T	C	d	C	D											
1/2	15	10.7	27.5	34	2.85	16	10.7	16	19	90	42	72	147	9	9	36	42	6	6	F03-F04
3/4	20	15.2	27.5	34	2.85	20	15.2	20	23	90	49	79	147	9	9	36	50	6	7	F03-F05
1	25	22.6	43.5	50.5	2.85	26	22.6	26	29	100	58	90	177	11	11	42	50	6	7	F04-F05
1 1/4	32	31.3	43.5	50.5	2.85	32	32.0	32	35	110	63	94	177	11	11	42	70	6	9	F04-F07
1 1/2	40	35.6	43.5	50.5	2.85	38	35.6	35.6	41	125	71	103	197	14	14	50	70	7	9	F05-F07
2	50	48.6	56.5	64	2.85	50	48.6	48.6	53	150	78	110	197	14	14	50	70	7	9	F05-F07
2 1/2	65	60.3	83.5	91	2.85	66	60.3	60.3	70	190	100	150	267	17	17	70	102	9	11	F07-F10
3	80	72.9	97.0	106	2.85	81	72.9	72.9	85	220	109	159	300	17	17	70	102	9	11	F07-F10
4	100	97.6	110	119	2.85	100	97.6	97.6	104	270	140	212	400	22	22	—	102	—	11	F10