

QUALITY FEATURES

RESILIENT SEATED VALVES

SUMMARY OF THE PRODUCT ADVANTAGES

- 1 The shaft safety device prevents inadvertant shaft removal when fitting actuators or undertaking maintenance procedures.
- 2 EBRO Butterfly valves comply with the requirements of the Heating System regulations dated 1st June 1994.
- 3 The special construction of the liner* (incorporating location beads for positioning within the body to prevent „working“ in operation) efficiently seals against the medium, the shaft locations and the connecting pipeworks flanges. Supplementary gasket seals for the adjacent flanges are not required.
- 4 The sealing surface of the disc being mirror finished guarentees the benefit of low operating torque and tight valve sealing up to the maximum working pressure 16 bars. This design gives high flow characteristics.
- 5 The valve body is completely precision machined in order that the valve liner with shaft locations can be accurately positioned to ensure minimal operational wear and an extended reliable service life.
- 6 The shaft is carried in multiple bearings with shaft deflection due to high pressure being prevented, thus ensuring optimal guidance, positive location and long service life.

* See picture 2

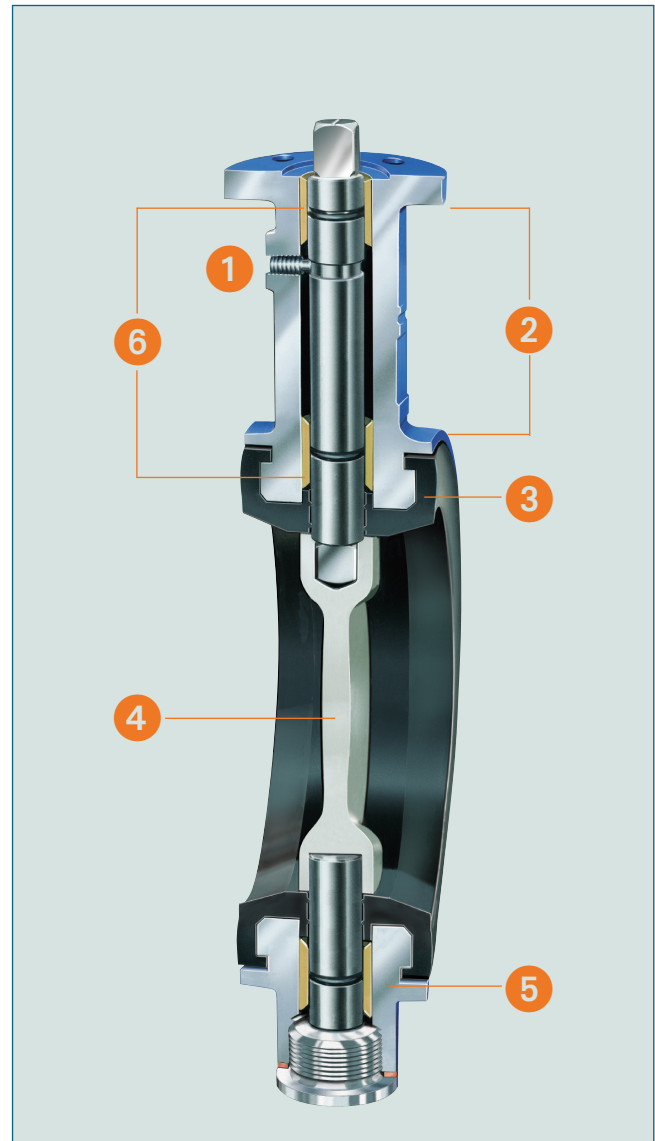

picture 1

- 1 Around the centre of the whole circumference of the liner is a raised locating ring to engage with an corresponding recess in the valve body, thus assuring the exact position of the liner.
- 2 Positive location and retention of the liner within the body is by means of circumferential lug profiles on the liner with matching recesses in the body.
- 3 The collars at the shaft locations ensure accurate positioning of the liner within the valve body (sizes DN 250 and larger have an integral vulcanized in steel ring).
- 4 The end connection sealing faces of the liner have a convex form. During assembly of the valve into the pipeline controlled deformation of the volume of the liner achieved when clamping between flanges (see picture 1). This controlled deformation restricts any increase in operating torque and eliminates damage to or destruction of the elastomers.



picture 2