

Eurovalve UK Limited  
 Unit 1D Campbell Way  
 ☎ (01909) 530444  
 Fax: (01909) 530044  
 Email: [sales@eurovalve.co.uk](mailto:sales@eurovalve.co.uk)

## Description

Centric butterfly valve with elastomer liner for liquids and gases in the industrial range, general services, water treatment, ...

## Product features

- Body construction DP1 Wafer DN 25-600  
DP3 Lug DN 50-600
- Face to face dimension according to ISO 5752/20, EN 558-1/20
- Top flange according to EN ISO 5211
- Max. working pressure 16/20 bar
- Rating PN6, PN10, PN16, PN25, ANSI cl. 150
- Temperature range -40°C ÷ 200°C according to material
- Tightness test according to EN 12266-1/P12 leakage rate A, test fluid water



The butterfly valves DESPONIA plus meet the safety requirements of the pressure Equipments Directive 2014/68/EU (PED) appendix 1 for fluids of the groups 1 and 2.



Butterfly valves DESPONIA plus are suitable to be operated in safety related systems according to IEC 61508 / 61511, Safety Integrity Level SIL 2

## Construction

1	Body (extended valve neck allowing insulation)
2	Blow out proof shaft with position indication
3	Disc
4	Exchangeable liner with sealing grooves on the tightening face
5	Self-lubricating shaft bushing
6	Square driven disc
7	External shaft sealing
8	Retaining washer (blow out protection)

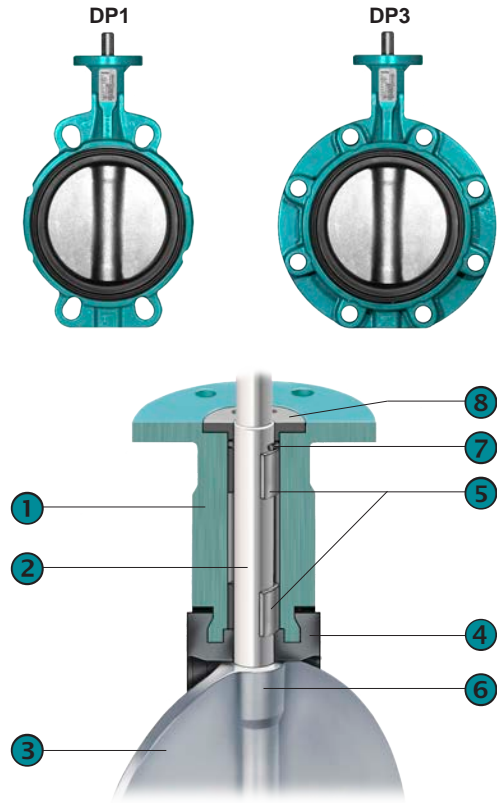

## Type code

DP1	100	. 3	3	. 2AE	. 4A	. 2AR	. E
①	②	③	④	⑤	⑥	⑦	⑧

①	Body type	DP1	Wafer	DN25-600
		DP3	Lug	DN50-600
②	Nominal diameter	025-600	mm	
③	Working pressure	→	1 = 6 bar, 2 = 10bar, 3 = 16bar, 4 = 20bar (with body 3HE or 4C0, for 2AE body consult our technical department)	
④	Rating	→	1 = PN6, 2 = PN10, 3 = PN16, A = ANSI cl. 150, 5 = PN25 on request	
⑤	Body	2AE	Ductile iron EN-GJS-400-15, Polyurethan coated 70µ	< 140°C DP1+DP3, DN25-400
		3HE	Cast steel GP240GH, 1.0619, Polyurethan coated 70µ	< 140°C DP1 DN50-600, DP3 DN50-600
		4C0	Stainless steel 1.4408, AISI316	DP1 DN50-600, DP3 DN50-600
⑥	Shaft	41	Stainless steel 1.4021, AISI420 (max. 16 bar)	DN 25-300
		42	Stainless steel 1.4542 / 17-4PH	DN 25-300
		4A	Stainless steel 1.4021, AISI420 (max. 16 bar)	DN 350-600
		4L	Stainless steel 1.4542 / 17-4PH	DN 350-600
⑦	Disc	2AR	Ductile iron EN-GJS-400-15, Rilsan coated 250µ (max. 16 bar)	< 90°C <16 bar DN25-600
		2AE	Ductile iron EN-GJS-400-15, Polyurethan coated 70µ (max. 16 bar)	< 120°C DN25-600
		3HE	Cast steel GP240GH, 1.0619, Polyurethan coated 70µ	< 120°C DN250-600
		3OD	Carbon steel 1.0552 / GS52.3, Ultralene Coating™ coated < 80°C, pmax. 10 ≤ DN400 / 6 bar > DN400	DN80-300
		4CP	Stainless steel 1.4408, AISI316	DN25-600
		4CP	Stainless steel 1.4408, AISI316, polished (max. 16 bar)	DN25-600
		4S0	Super austenitic steel 1.4588	DN40-600
⑧	Liner	E	EPDM < 95°C	EC = EPDM HT < 130°C V = FPM (Viton) < 200°C <16 bar
		N	Nitril (NBR) < 100°C	H = CSM (Hypalon) < 110°C <16 bar
		Other materials and white liners on request		S = MVQ (Silicone) <200°C <6bar

Max. pressure and temperature limits of application are dependent of the working conditions.



When mounting the valve at the end of a line please note:

- Body type	DP3
- Medium	only for liquids, 10÷30°C
- Max. working pressure	DN25-200 10 bar
(with 16 bar disc)	DN250-600 6 bar
- no water hammer !!!	
please consult our document "Flanges"	

Dimensions

DP1 Wafer, DN 25-600

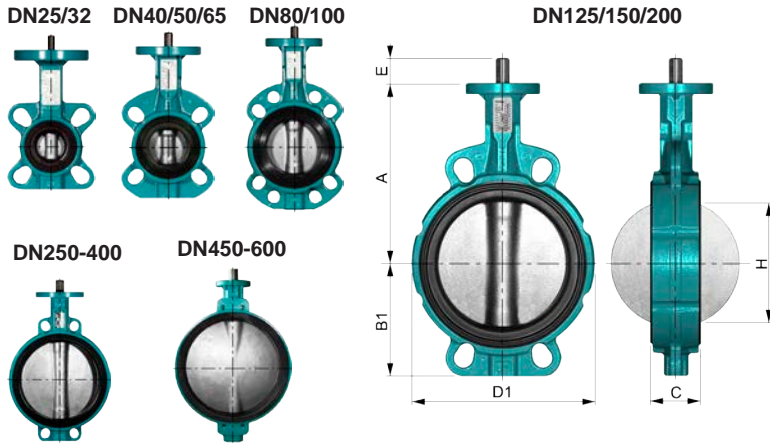

DN	A	B1	C	D1	E	H*	x*	[kg]
25/32	110	51	30	101	12	19	3	1,4
40	130	54	33	108	12	28	6	2,0
50	135	72	43	120	12	32	6	3,0
65	150	82	46	138	12	50	11	3,6
80	160	92	46	142	12	69	19	4,0
100	180	102	52	162	12	88	26	5,5
125	195	120	56	189	16	115	36	7,5
150	210	133	56	214	16	141	48	8,6
200	240	166	60	270	19	194	72	12,7
250	279	201	68	324	24	240	91	22,2
300	315	234	78	378	24	290	112	30,8
350	330	268	80	425	40	330	130	41,5
400	365	299	102	475	40	377	145	57,2
450	397	355	113	538	65	425	164	95,0
500	437	393	126	595	65	474	182	125
600	522	464	153	695	80	569	218	180

\* When using plastic stubs please check dimension H/x to avoid disc damaging

DP3 LUG body, DN 50-600

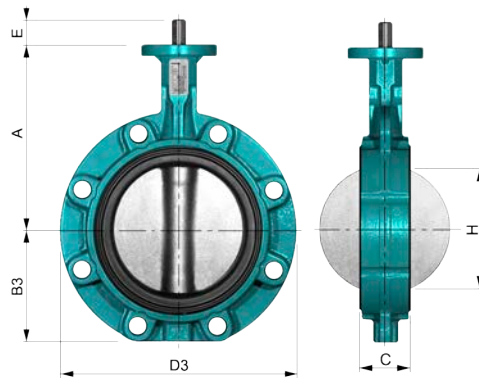

DN	A	B3	C	D3	E	H*	x*	[kg]
50	135	72	43	116	12	32	6	3,2
65	150	82	46	131	12	50	11	4,0
80	160	88	46	188	12	69	19	6,1
100	180	102	52	219	12	88	26	8,5
125	195	116	56	248	16	115	36	10,0
150	210	128	56	274	16	141	48	11,0
200	240	161	60	332	19	194	72	19,6
250	279	199	68	402	24	240	91	28,7
300	315	234	78	472	24	290	112	41,2
350	330	258	80	520	40	330	130	55,0
400	365	290	102	584	40	377	145	75,0
450	397	355	113	655	65	425	164	150
500	437	393	126	712	65	474	182	170
600	522	464	153	829	80	569	218	240

Top flange according to EN ISO 5211

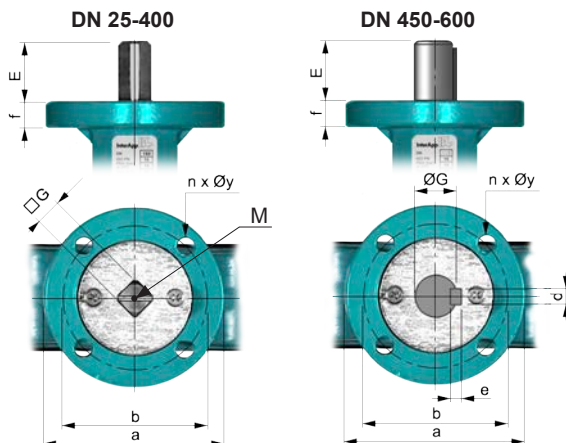

DN	E	G	M	d	e	f	ISO	a	b	n x øy
25/32	12	□ 8	M4	-	-	12	F07	90	70	4 x 9
40	12	□ 8	M4	-	-	12	F07	90	70	4 x 9
50	12	□ 11	M6	-	-	12	F07	90	70	4 x 9
65	12	□ 11	M6	-	-	12	F07	90	70	4 x 9
80	12	□ 11	M6	-	-	12	F07	90	70	4 x 9
100	12	□ 11	M6	-	-	12	F07	90	70	4 x 9
125	16	□ 14	M6	-	-	12	F07	90	70	4 x 9
150	16	□ 14	M6	-	-	12	F07	90	70	4 x 9
200	19	□ 17	M6	-	-	12	F07	90	70	4 x 9
250	24	□ 22	-	-	-	18	F10/F12	155	102/125	4 x 10 / 4 x 13
300	24	□ 22	-	-	-	18	F10/F12	155	102/125	4 x 10 / 4 x 13
350	40	□ 22	-	-	-	18	F12	155	125	4 x 13
400	40	□ 27	-	-	-	18	F12	155	125	4 x 13
450	65	ø 45	-	14	9	25	F14	175	140	4 x 18
500	65	ø 45	-	14	9	25	F14	175	140	4 x 18
600	80	ø 70	-	20	12	25	F16	220	165	4 x 22

Further documentation

Pneumatic actuators, Electric actuators, Accessories according separate data sheets.  
 Installation guide, Maintenance guide, Flanges: Please consult these guides for the installation and maintenance of our butterfly valves.

[www.eurovalve.co.uk](http://www.eurovalve.co.uk)

Eurovalve UK Limited  
 Unit 1D Campbell Way  
 ☎ (01909) 530444  
 ☎ (01909) 530044