

From NPS ½" up to NPS 1¼"

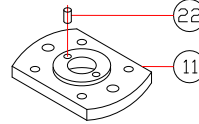

From NPS 6" up to NPS 8"

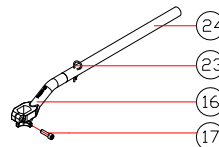

\* 2 up to NPS 6", 3 from NPS 8"  
\*\* 2 up to NPS 4", 4 from NPS 6"

**Table 1**

Pos.	Quant.	Description
1	1	Body 1
2	1	Body 2
•• 3	1	Ball
• 4	2	Seat
•• 5	1	Stem
• 6	1	Stem seal
• 7	1	Stem packing
• 7d	1	Stem packing d
8	1	Gland packing
8a	1	Gland packing a
9	*	Spring washer
11	1	Cover
13a	**	Cover bolt 1
13b	2	Cover bolt 2 (2),(3)
• 14	1	Body seal 1
15	-	Body bolt
16	1	Handle
17	1	Handle bolt
•• 19	1	Spring
•• 20	1	Antistatic ball
22	2	Stop pin (1)
23	1	Handle pin (3)
24	1	Lengthening handle (3)
• 34	1	Body seal 2
• 35	1	Stem O-ring
50	1	Subjection ring
110	1	Subjection ring seal (3)
• 165	1	Stem bearing

- (1) From NPS ½" up to NPS 1 ¼"
- (2) From NPS 1 ½" up to NPS 4"
- (3) From NPS 6" up to NPS 8"

- Start-up: 5% of ordered quantity
- SOFT PARTS KIT
- METALLIC PARTS

Suggested materials to be checked at least every five (5) year service.  
**See point 5 (Maintenance)**

Torque screw tightness values for bolts (Nr. 15) can be found attached in document DC-08-07-03 PF "Screw torque"

**Table 2**

NPS	Bolt
½" - 1 ½"	M 8
2" - 2 ½"	M 10
3" - 4"	M 12
6" - 8"	M 16

**1. SCOPE**

This manual is intended as a guide to assist customers or end-users in the correct storage, installation and maintenance of PEKOS floating valves.

**2. APPLICABILITY**

This manual is applicable to PEKOS floating ball valves (Z system) as per norm ANSI two pieces with full bore and 2 ways. Nominal sizes and pressures covered by this manual: Class 150 NPS ½" - 8", Class 300 NPS ½" - 4", Class 600 NPS ½"-2".

**3. STORAGE**

**3.1 Supplying conditions**

Cast iron and carbon steel ball valves are supplied with a phosphatising treatment to protect against corrosion. These conditions are standard, but they can be changed on demand.

**3.2 Maintenance during the storage**

- a. Stainless steel and carbon steel valves should be stored separately, to protect the stainless steel against corrosion.
- b. Valves must remain in open position with plastic end covers fitted.
- c. If possible it would be advisable to leave the ball valves in their own packing cases.
- d. Valves to be stored for a long time shall be checked by the quality control personnel every 6 months.
- e. Degreased valves shall only be unpacked before installation.

**3.3 Environment conditions**

- a. Valves shall be stored in dry conditions. Other corrosive environment conditions must be also avoided.
- b. Valves must be protected against ambient dust.

	<b>MANUAL INSTRUCTION</b> FOR STORAGE, INSTALLATION, OPERATION AND MAINTENANCE OF PEKOS BALL VALVES	<b>ANSI</b> Z System Floating ball Class 150(NPS ½" - 8") Class 300(NPS ½" - 4") Class 600(NPS ½" - 2")	<b>Nr.104</b> 28/05/18 Rev.6
---	---	---	------------------------------------

#### 4. INSTALLATION

- a. Verify that valves have not been damaged during transit. Inspect inside of the valves and the pipeline of the installation to be able to verify there are no strange particles.
- b. It is advisable to use protective filters during the installation and check-in period while the possibility of dirt or even oxidation of the pipes exists. They have to be used until pipes are absolutely free of particles in suspension.
- c. If possible, valve shall be mounted in such way to allow periodic inspections.
- d. Valves are bidirectional, so fluid can run in both directions.
- e. Valves can be mounted in any position but it is advisable to mount the valves with the stem in vertical position.
- f. It is necessary to obtain correct alignment and parallelism to avoid any kind of stress.
- g. Once the installation is completed, valve must be operated for at least one opening and closing action to ensure perfect operation.
- h. After cleaning, protective filters could be removed.
- i. Protective filters should remain installed on dirty applications.

#### 5. MAINTENANCE

Pekos recommends inspecting the valves at least every five (5) years. These inspection intervals could be affected by the process service (fluid, temperature, service, and cycles), and environmental condition.

##### 5.1 Valves revision

PEKOS ball valves do not need lubrication and the packing does not need maintenance.

*Seats (4), stem packing (7 and 7d), body seals (14 and 34), ball (3) and stem (5)* can be replaced easily using common tools. As replacement pieces is advisable to follow the instructions below table1 in page 1.

Prior to carrying out work on valves the pipeline must be completely empty, including the ball valve body cavity by half opening valve to allow any pressure build up to escape.

Care must be taken to avoid contact with dangerous or toxic chemical products. The valves must be thoroughly cleaned, in particular the body cavity, before handling and dismantling.

##### 5.2 Stem leakage

The packing system of the *stem (5)* of PEKOS ANSI ball valves has been designed for a long life. The *spring washers (9)* compensate any looseness inside the packing. In case of leakage, the stem seals shall be replaced as it is shown:

- a. If the valve contains handle, loosen the *handle bolt (17)* and remove the *handle (16)*.
- b. Loosen the *cover bolts (13a and 13b)* and remove the *cover (11)*.
- c. Remove the *spring washers (9)*, the *gland packing (8 and 8a)* and the *stem packing (7 and 7d)*, and replace them.
- d. Reassemble the pieces accordingly as it is indicated in point 6.

##### 5.3 Body leakage

These ANSI floating ball valves are constructed in 2 pieces, *body1 (1)* and *body2 (2)*. Body fasteners should be checked (table 2, page 1) for tightness. If leakage occurs and if necessary, *body seals (14 and 34)* should be replaced as it is shown:

- a. Make alignment marks on the *body (1)* and *ends (2)* prior to dismantling, to ensure a correct alignment when reassembling. Remove *body bolts (15)* and disassemble *body2 (2)*.
- b. Substitute the *body seals (14 and 34)*.
- c. Reassemble the pieces accordingly as it is indicated in point 6.

##### 5.4 Seat leakage

If leakage occurs, *seats (4)* must be replaced as it is shown:

- a. Maintaining the valve in the closed position; loosen and remove *body bolts (15)* and remove *body2 (2)* from *body1 (1)* to check the *ball (3)* and the *seats (4)*. To remove the *ball (3)*, if necessary, bang it with a soft tool gently.
- b. Check the rest of components, and replace them if necessary.
- c. Assemble the pieces accordingly as it is indicated in point 6.

#### 6. RE-ASSEMBLY

- a. Prior to re-assembly all components and body cavity should be cleaned of any incrustation, dirt, rust etc., especially in the locations of seats & seals.
- b. Put the *seats (4)* into their housings of the *body1 (1)* and the *body2 (2)*. Check if they are well settled, and if necessary bang it with a soft tool gently.
- c. Put the *stem seal (6)* and the *stem o-ring (35)* onto the *stem (5)*. Check the antistatic devices (pos. 19, 20).
- d. Assemble the *stem (5)* into the valve as the arrow shows in the principal figure.
- e. Assemble the following components into the *body 1 (1)* introducing them through the *stem (5)* in this order: *stem packing (7)*, *gland packing (8)*, *stem packing d (7d)*, *gland packing a (8a)* and *spring washers (9)*, putting the *stem (5)* in closed position.
- f. Assemble the *stem bearing (165)* in the *cover (11)*, and put both of them in the body introducing through the *stem (5)*. Match them to the *body 1 (1)* by means of the *cover bolts (13a and 13b)*. Put the *subjection ring seal (110)* and the *subjection ring (50)*.
- g. Introduce carefully the *ball (3)* into the *body 1 (1)* aligning the ball groove with the stem.
- h. Put the *body seals (14 and 34)* into their housing of the *body 2 (2)*.
- i. Maintaining the valve in its closed position and ensuring that alignment marks are matched, joint the *body 1 (1)* and the *body 2 (2)*. Assemble the *body bolts (15)* evenly tighten in diagonal using a torque wrench and the values indicated attached in document DC-08-07-03 PF "Screw torque".
- j. If the valve contains handle, put the *handle (16)* into its housing in the *stem (5)*, and tighten the *handle bolt (17)*.
- k. Slowly cycle the valve until completing 1 cycle to ensure coupling between the *seats (4)* and the *ball (3)*.
- l. Carefully cycle the valve twice in order to check the correct working. Stem should rotate smoothly offering resistance as indicated by the manufacturers torque figures. Tests should be carried out according to API598, at the pressure rating that corresponds to the valve, before reinstallation.

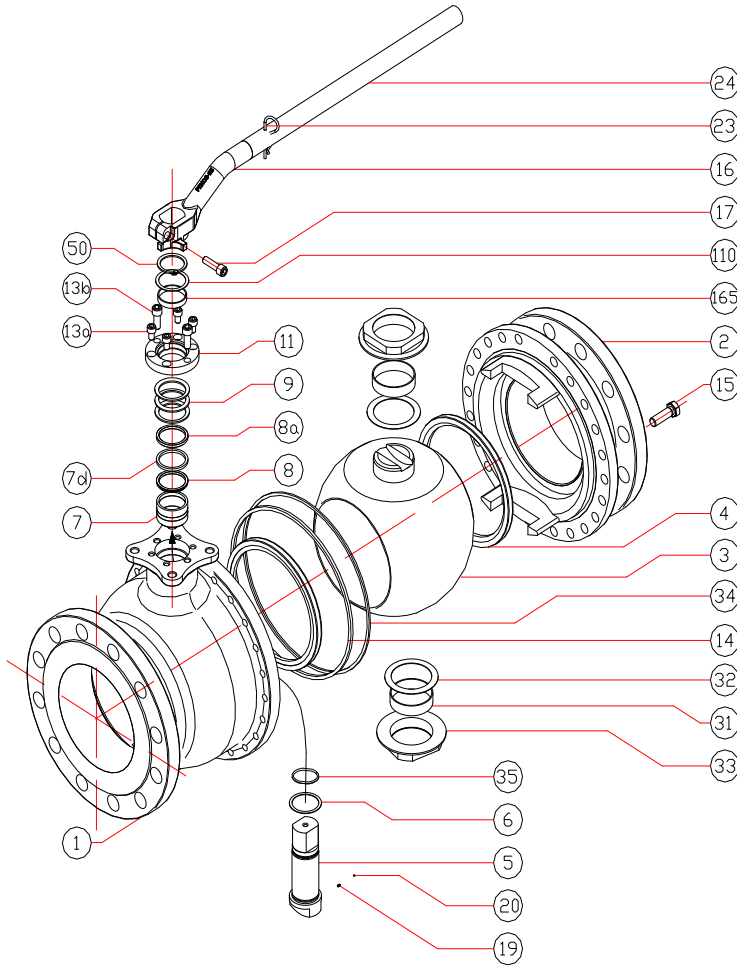

**Table 1**

Pos.	Quant.	Description
1	1	Body 1
2	1	Body 2
•• 3	1	Ball
• 4	2	Seat
•• 5	1	Stem
• 6	1	Stem seal
• 7	1	Stem packing
• 7d	1	Stem packing d
8	1	Gland packing
8a	1	Gland packing a
9	*	Spring washer
11	1	Cover
13a	4	Cover bolt 1
13b	2	Cover bolt 2
• 14	1	Body seal 1
15	-	Body bolt
16	1	Handle
17	1	Handle bolt
•• 19	1	Spring
•• 20	1	Antistatic ball
23	1	Handle pin
24	1	Lengthening handle
• 31	2	Bearing
• 32	2	Bearing disc
33	2	Support bearing
• 34	1	Body seal 2
• 35	1	Stem O-ring
50	1	Subjection ring
110	1	Subjection ring seal
• 165	1	Stem bearing

\* 2 up to NPS 6", 3 from NPS 8"

- Start-up: 5% of ordered quantity
- SOFT PARTS
- METALLIC PARTS

Suggested materials to be checked at least every five (5) year service.  
**See point 5 (Maintenance)**

Torque screw tightness values for bolts (Nr. 15) can be found attached in document DC-08-07-03 PF "Screw torque"

**Table 2**

NPS	Bolt
6" – 8"	M 16
10" – 12"	M 20

**1. SCOPE**

This manual is intended as a guide to assist customers or end-users in the correct storage, installation and maintenance of PEKOS guided valves.

**2. APPLICABILITY**

This manual is applicable to PEKOS guided ball valves (Z system) as per norm ANSI two pieces with full bore and 2 ways. Nominal sizes and pressures covered by this manual: Class150 NPS 6"-12" / Class300 NPS 6"-12".

**3. STORAGE**

**3.1 Supplying conditions**

Cast iron and carbon steel ball valves are supplied with a phosphatising treatment to protect against corrosion. These conditions are standard, but they can be changed on demand.

**3.2 Maintenance during the storage**

- a. Stainless steel and carbon steel valves should be stored separately, to protect the stainless steel against corrosion.
- b. Valves must remain in open position with plastic end covers fitted.
- c. If possible it would be advisable to leave the ball valves in their own packing cases.
- d. Valves to be stored for a long time shall be checked by the quality control personnel every 6 months.
- e. Degreased valves shall only be unpacked before installation.

**3.3 Environment conditions**

- a. Valves shall be stored in dry conditions. Other corrosive environment conditions must be also avoided.
- b. Valves must be protected against ambient dust.

	<b>MANUAL INSTRUCTION</b> FOR STORAGE, INSTALLATION, OPERATION AND MAINTENANCE OF PEKOS BALL VALVES	<b>ANSI</b> Z System Guided ball NPS 6"-12" (Class150) NPS 6"-12" (Class300)	<b>Nr.105</b> 23/02/18 Rev.5
---	---	---	------------------------------------

#### 4. INSTALLATION

- a. Verify that valves have not been damaged during transit. Inspect inside of the valves and the pipeline of the installation to be able to verify there are no strange particles.
- b. It is advisable to use protective filters during the installation and check-in period while the possibility of dirt or even oxidation of the pipes exists. They have to be used until pipes are absolutely free of particles in suspension.
- c. If possible, valve shall be mounted in such way to allow periodic inspections.
- d. Valves are bidirectional, so fluid can run in both directions.
- e. Valves can be mounted in any position but it is advisable to mount the valves with the stem in vertical position.
- f. It is necessary to obtain correct alignment and parallelism to avoid any kind of stress.
- g. Once the installation is completed, valve must be operated for at least one opening and closing action to ensure perfect operation.
- h. After cleaning, protective filters could be removed.
- i. Protective filters should remain installed on dirty applications.

#### 5. MAINTENANCE

Pekos recommends inspecting the valves at least every five (5) years. These inspection intervals could be affected by the process service (fluid, temperature, service, and cycles), and environmental condition.

##### 5.1 Valves revision

PEKOS ball valves do not need lubrication and the packing does not need maintenance.

*Seats (4), stem packing (7 and 7d), body seals (14 and 34), ball (3) and stem (5)* can be replaced easily using common tools. As replacement pieces is advisable to follow the instructions below table1 in page 1.

Prior to carrying out work on valves the pipeline must be completely empty, including the ball valve body cavity by half opening valve to allow any pressure build up to escape.

Care must be taken to avoid contact with dangerous or toxic chemical products. The valves must be thoroughly cleaned, in particular the body cavity, before handling and dismantling.

##### 5.2 Stem leakage

The packing system of the *stem (5)* of PEKOS ANSI ball valves has been designed for a long life. The *spring washers (9)* compensate any looseness inside the packing. In case of leakage, the stem seals shall be replaced as it is shown:

- a. If the valve contains handle, loosen the *handle bolt (17)* and remove the *handle (16)*.
- b. Loosen the *cover bolts (13a and 13b)* and remove the *cover (11)*.
- c. Remove the *spring washers (9)*, the *gland packing (8 and 8a)* and the *stem packing (7 and 7d)*, and replace them.
- d. Reassemble the pieces accordingly as it is indicated in point 6.

##### 5.3 Body leakage

These ANSI guided ball valves are constructed in 2 pieces, *body1 (1)* and *body2 (2)*. Body fasteners should be checked (table 2, page 1) for tightness. If leakage occurs and if necessary, *body seals (14 and 34)* should be replaced as it is shown:

- a. Make alignment marks on the *body (1)* and *end cap (2)* prior to dismantling, to ensure a correct alignment when reassembling. Remove *body bolts (15)* and disassemble *body2 (2)*.
- b. Substitute the *body seals (14 and 34)*.
- c. Reassemble the pieces accordingly as it is indicated in point 6.

##### 5.4 Seat leakage

If leakage occurs, *seats (4)* must be replaced as it is shown:

- a. Maintaining the valve in the closed position; loosen and remove *body bolts (15)* and remove *body2 (2)* from *body1 (1)* to check the *ball (3)* and the *seats (4)*. To remove the *ball (3)*, if necessary, bang it with a soft tool gently.
- b. Check the rest of components, and replace them if necessary.
- c. Assemble the pieces accordingly as it is indicated in point 6.

#### 6. RE-ASSEMBLY

- a. Prior to re-assembly all components and body cavity should be cleaned of any incrustation, dirt, rust etc., especially in the locations of seats & seals.
- b. Put the *seats (4)* into their housings of the *body1 (1)* and the *body2 (2)*. Check if they are well settled, and if necessary bang it with a soft tool gently.
- c. Put the *stem seal (6)* and the *stem o-ring (35)* onto the *stem (5)*. Check the antistatic devices (pos. 19, 20).
- d. Assemble the *stem (5)* into the valve as the arrow shows in the principal figure.
- e. Assemble the following components into the *body 1 (1)* introducing them through the stem (5) in this order: *stem packing (7)*, *gland packing (8)*, *stem packing d (7d)*, *gland packing a (8a)* and *spring washers (9)*, putting the *stem (5)* in closed position.
- f. Assemble the *stem bearing (165)* in the *cover (11)*, and put both of them in the body introducing through the *stem (5)*. Match them to the *body 1 (1)* by means of the *cover bolts (13a and 13b)*.
- g. Put the *bearing (31)* into the *support bearing (33)*. Assemble the *bearing disc (32)* and the support *bearing (33)* in the stump of the *ball (3)*.
- h. Introduce carefully the *ball (3)* into the *body 1 (1)* aligning the ball groove with the stem.
- i. Put the *body seals (14 and 34)* into their housing of the *body 2 (2)*.
- j. Maintaining the valve in its closed position and ensuring that alignment marks are matched, joint the *body 1 (1)* and the *body 2 (2)*. Assemble the *body bolts (15)* evenly tighten in diagonal using a torque wrench and the values indicated attached in document DC-08-07-03 PF "Screw torque".
- k. Put the *subjection ring seal (110)* and the *subjection ring (50)*.
- l. If the valve contains handle, put the *handle (16)* into its housing in the *stem (5)*, and tighten the *handle bolt (17)*.
- m. Slowly cycle the valve until completing 1 cycle to ensure coupling between the *seats (4)* and the *ball (3)*.

	<b>MANUAL INSTRUCTION</b> FOR STORAGE, INSTALLATION, OPERATION AND MAINTENANCE OF PEKOS BALL VALVES	<b>ANSI</b> Z System Guided ball NPS 6"-12" (Class150) NPS 6"-12" (Class300)	<b>Nr.105</b> 23/02/18 Rev.5
---	---	---	------------------------------------

- n. Carefully cycle the valve twice in order to check the correct working. Stem should rotate smoothly offering resistance as indicated by the manufacturers torque figures. Tests should be carried out according to API 598, at the pressure rating that corresponds to the valve, before reinstallation.