

CHECK VALVES

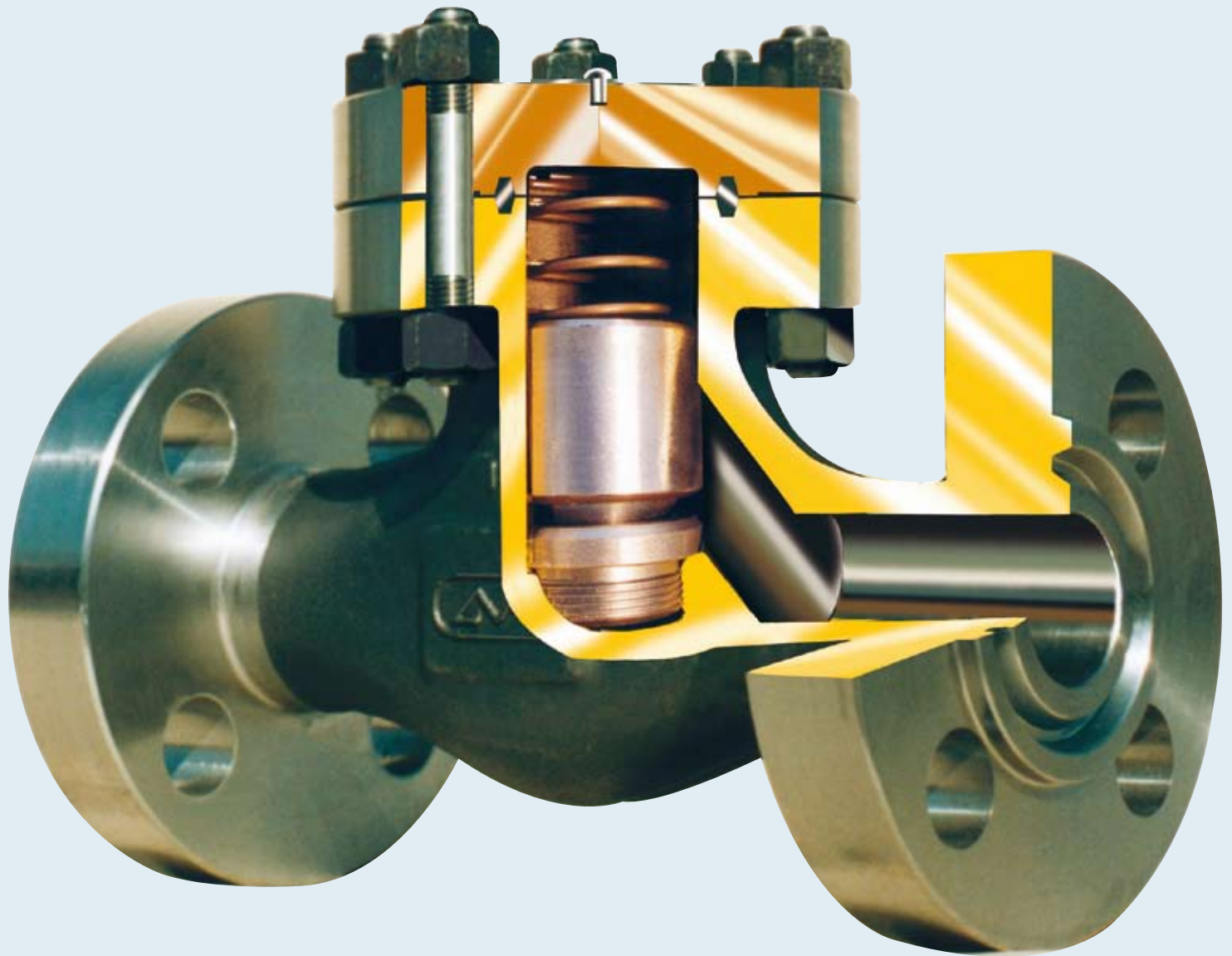

CHECK

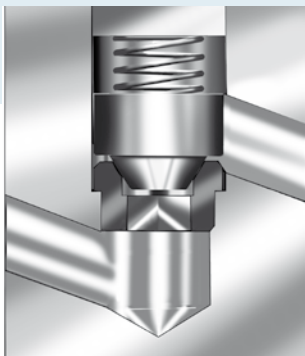

Piston type Fig. n° 300

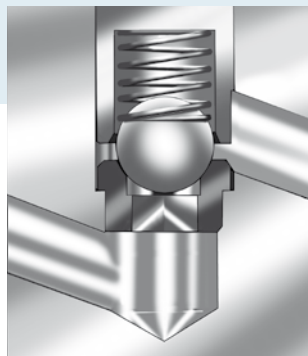

Ball type Fig. n° 400

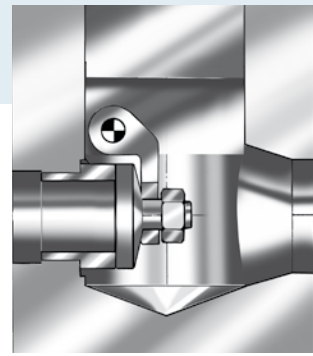

Swing type Fig. n° 500

800 BOLTED COVER Standard & Reduced bore

Std. bore		Red. bore		A	B	B	C	Kg
Size	Fig. n	Size	Fig. n°	End to end	Dia of port PISTON/BALL	Dia of port SWING	Center to top	Weight
1/4	B 301			80	7	-	49	1,1
3/8	B 302	1/2	BR 303	80	9	10	49	1,1
1/2	B 303	3/4	BR 304	90	12,5	14	55	1,8
3/4	B 304	1	BR 305	110	17,5	18	70	2,6
1	B 305	1 1/4	BR 306	127	22,5	24	77	3,6
1 1/4	B 306	1 1/2	BR 307	• 155	29	29,5	105	5,5
1 1/2	B 307	2	BR 308	• 170	35	36,5	120	8,4
2	B 308			• 210	45	48	145	11,8

• For swing type end to end: $\varnothing 1^{1/4} = 127 - \varnothing 1^{1/2} = 130 - \varnothing 2 = 150/210$

1500 BOLTED COVER Standard & Reduced bore

Std. bore		Red. bore		A	B	B	C	Kg
Size	Fig. n	Size	Fig. n°	End to end	Dia of port PISTON/BALL	Dia of port SWING	Center to top	Weight
1/4	9B 301			90	7	-	55	2,2
3/8	9B 302	1/2	9BR 303	90	9	10	55	2,2
1/2	9B 303	3/4	9BR 304	110	11	14	70	3,1
3/4	9B 304	1	9BR 305	120	14,5	18	77	4,2
1	9B 305	1 1/4	9BR 306	130	19	24	105	5,8
1 1/4	9B 306	1 1/2	9BR 307	• 170	27	29,5	115	9,4
1 1/2	9B 307	2	9BR 308	210	31	36	145	12,1
2	9B 308			210	37,5	40	145	13,5

• For swing type end to end: $\varnothing 1^{1/4} = 130$

1500 ROUND BOLTED COVER Standard bore

Standard bore		A	B	B	C	Kg
Size	Fig. n°	End to end	Dia of port PISTON/BALL	Dia of port SWING	Center to top	Weight
1/4	15B 301	110	7	-	90	5,7
3/8	15B 302	110	8	10	90	5,7
1/2	15B 303	110	11	14	90	5,7
3/4	15B 304	120	14,5	18	105	7,1
1	15B 305	130	19	24	120	7,9
1 1/2	15B 307	210	31	36	160	19
2	15B 308	240	37,5	40	170	19,5

2500 ROUND BOLTED COVER Standard bore

Standard bore		A	B	B	C	Kg
Size	Fig. n°	End to end	Dia of port PISTON/BALL	Dia of port SWING	Center to top	Weight
1/4	25B 301	110	7	-	105	7
3/8	25B 302	110	8	10	105	7
1/2	25B 303	110	11	10	105	7
3/4	25B 304	120	14	14	110	7,2
1	25B 305	130	19	19	125	9,
1 1/2	25B 307	210	28	30	160	24
2	25B 308	240	36	36,5	170	26

Welded cover

800 WELDED COVER Standard & Reduced bore

Std. bore		Red. bore		A	B	B	C	Kg
Size	Fig. n	Size	Fig. n°	End to end	Dia of port PISTON/BALL	Dia of port SWING	Center to top	Weight
1/4	W 301			80	7	-	49	0,9
3/8	W 302	1/2	WR 303	80	9	10	49	0,9
1/2	W 303	3/4	WR 304	90	12,5	14	56	1,2
3/4	W 304	1	WR 305	110	17,5	18	69	2,1
1	W 305	1 1/4	WR 306	127	22,5	24	80	3,4
1 1/4	W 306	1 1/2	WR 307	• 155	29	29,5	95	5,3
1 1/2	W 307	2	WR 308	• 170	35	36,5	105	7,8
2	W 308			• 210	45	48	125	10,9

• For swing type end to end: $\varnothing 1^{1/4} = 127 - \varnothing 1^{1/2} = 130 - \varnothing 2 = 150/210$

1500 WELDED COVER Standard & Reduced bore

Std. bore		Red. bore		A	B	B	C	Kg
Size	Fig. n	Size	Fig. n°	End to end	Dia of port PISTON/BALL	Dia of port SWING	Center to top	Weight
1/4	15W 301			90	7	-	55	1,3
3/8	15W 302	1/2	15WR 303	90	9	10	55	1,3
1/2	15W 303	3/4	15WR 304	110	11	14	70	2,5
3/4	15W 304	1	15WR 305	120	14,5	18	80	3,8
1	15W 305	1 1/4	15WR 306	130	19	24	90	5,5
1 1/4	15W 306	1 1/2	15WR 307	• 170	27	29,5	100	8,3
1 1/2	15W 307	2	15WR 308	210	31	36	115	11
2	15W 308			210	37,5	40	130	12,5

• For swing type end to end: $\varnothing 1^{1/4} = 130$

2500 WELDED COVER Standard bore

Standard bore		A	B	B	C	Kg
Size	Fig. n°	End to end	Dia of port PISTON/BALL	Dia of port SWING	Center to top	Weight
1/4	25W 301	110	7	-	70	2,8
3/8	25W 302	110	8	10	70	2,8
1/2	25W 303	110	11	10	70	2,8
3/4	25W 304	120	14	14	85	4,5
1	25W 305	130	19	18	90	6,2
1 1/4	25W 306	210	24	24	130	8,9
1 1/2	25W 307	210	28	29	130	8,9
2	25W 308	240	36	36	140	15

4500 WELDED COVER Standard bore

Standard bore		A	B	B	C	Kg
Size	Fig. n°	End to end	Dia of port PISTON/BALL	Dia of port SWING	Center to top	Weight
1/2	45W 313	120	8	-	85	4,5
3/4	45W 314	155	12	-	95	7
1	45W 315	155	15	-	95	7
1 1/2	45W 317	210	25	-	140	14
2	45W 318	240	28	-	140	15

Swing type on request

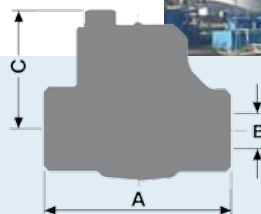

800 WELDED COVER - Standard bore

Threaded and socket weld ends

Standard bore		A	B	C	Kg
Size	Fig. n°	End to end	Dia of port	Centre to top	Weight
1/4	Y 311	80	7	60	1,5
3/8	Y 312	80	9	60	1,5
1/2	Y 313	80	12	60	1,5
3/4	Y 314	100	17,5	75	2,5
1	Y 315	110	22,5	80	3
1¼	Y 316	150	30	115	5,5
1½	Y 317	160	35	115	6
2	Y 318	190	46	140	9
2½	Y 319	210	48	160	18
3	Y 3110	280	65	200	30
• 4	Y 3112	368	70	260	41

• BW only

1500 WELDED COVER - Standard bore

Threaded and socket weld ends

Standard bore		A	B	C	Kg
Size	Fig. n°	End to end	Dia of port	Centre to top	Weight
1/4	15Y 311	100	7	75	2,5
3/8	15Y 312	100	9	75	2,5
1/2	15Y 313	100	13	75	2,5
3/4	15Y 314	110	17,5	80	3
1	15Y 315	125	22,5	85	4,5
1¼	15Y 316	150	28	115	5,5
1½	15Y 317	160	35	115	6
2	15Y 318	190	44	140	9
2½	15Y 319	216	46	160	18
3	15Y 3110	280	55	200	30
• 4	15Y 3112	368	62	260	42

• BW only

2500 WELDED COVER - Standard bore

Threaded and socket weld ends

Standard bore		A	B	C	Kg
Size	Fig. n°	End to end	Dia of port	Centre to top	Weight
1/4	25Y 311	110	7	80	3
3/8	25Y 312	110	10	80	3
1/2	25Y 313	110	12	80	3
3/4	25Y 314	125	15	85	4,5
1	25Y 315	160	20	115	5,5
1¼	25Y 316	160	25	115	6
1½	25Y 317	190	31	140	9
2	25Y 318	210	38	150	12
2½	25Y 319	280	44	200	31
• 3	25Y 3110	280	48	200	31
• 4	25Y 3112	368	52	260	42

• BW only

4500 WELDED COVER - Standard bore

Threaded and socket weld ends

Standard bore		A	B	C	Kg
Size	Fig. n°	End to end	Dia of port	Centre to top	Weight
1/4	45Y 311	110	7	85	4
3/8	45Y 312	110	7	85	4
1/2	45Y 313	125	8	100	5
3/4	45Y 314	160	11	125	7
1	45Y 315	190	15	140	9
1¼	45Y 316	190	18	140	9
1½	45Y 317	210	20	150	9
2	45Y 318	280	25	200	31
• 2½	45Y 319	280	28	200	32
• 3	45Y 3110	360	35	260	43
• 4	45Y 3112	360	40	260	44

• BW only

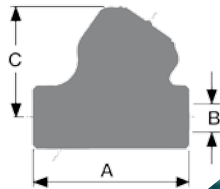

**Y PATTERN CHECK
WELDED COVER**
Standard bore
Piston & Ball type

1500 PRESSURE SEAL - Standard bore Butt welding ends

Standard bore		A	B	B	C	Kg
Size	Fig. n°	End to end	Dia of port PISTON/BALL	Dia of port TILTING	Center to top	Weight
• 1	15PS 315	130	18	-	115	6,5
• 1¼	15PS 316	180	28	-	140	9
• 1½	15PS 317	180/210	31	-	165	15
• 2	15PS 318	216	35	43	165	30
• 2½	15PS 319	254/368	40	50	220	36
• 3	15PS 3110	305/368	52	63	220	39
• 4	-	-	-	-	-	-
• 6	-	-	-	-	-	-
• 8	-	-	-	-	-	-

• On request

2500 PRESSURE SEAL - Standard bore Butt welding ends

Standard bore		A	B	B	C	Kg
Size	Fig. n°	End to end	Dia of port PISTON/BALL	Dia of port TILTING	Center to top	Weight
• 1	25PS 315	180	18	-	140	9
• 1¼	25PS 316	210	24	-	165	15
• 1½	25PS 317	210	29	-	165	15
• 2	25PS 318	280	35	43	165	31
• 2½	25PS 319	330	40	43	165	36
• 3	25PS 3110	368	52	52	220	39
• 4	-	-	-	-	-	-
• 6	-	-	-	-	-	-
• 8	-	-	-	-	-	-

• On request

4500 PRESSURE SEAL - Standard bore Butt welding ends

Standard bore		A	B	B	C	Kg
Size	Fig. n°	End to end	Dia of port PISTON/BALL	Dia of port TILTING	Center to top	Weight
• 1	45PS 315	180	12,5	-	140	9,5
• 1¼	45PS 316	210	16	-	165	16
• 1½	45PS 317	210	16	-	165	16
• 2	45PS 318	280	25	30	165	31
• 2½	45PS 319	330	30	30	220	36
• 3	45PS 3110	330	30	32	220	39
• 4	-	-	-	-	-	-
• 6	-	-	-	-	-	-
• 8	-	-	-	-	-	-

• On request

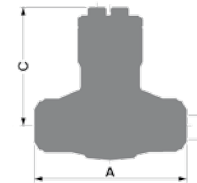

PRESSURE SEAL CHECK VALVES BOLTED COVER

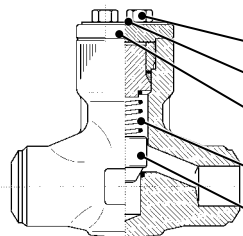

PISTON TYPE

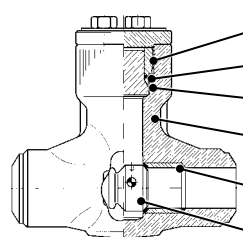

TILTING TYPE

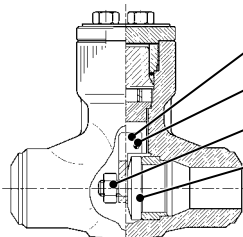

SWING TYPE

DESCRIPTION

- 1 BOLTS
- 2 NAME PLATE
- 3 STAND
- 4 SPRING
- 5 PISTON
- 6 BONNET NUT
- 7 PRESSURE SEAL RING
- 8 PRESSURE SEAL GASKET
- 9 BODY
- 10 SEAT
- 11 TILTING DISC
- 12 HINGE
- 13 HINGE PIN
- 14 SWING NUT
- 15 SWING



150 BOLTED & WELDED COVER

Standard bore - Integral flanged ends

Standard bore n°			A	B	B	C	Kg
Size	Bolted/B.	Welded/B.	End to end	Dia of port PISTON/BALL	Dia of port SWING	Center to top	Weight
1/2	1B 303	1W 303	108	12	14	76	2,6
3/4	1B 304	1W 304	118	16	18	80	3,8
1	1B 305	1W 305	127	21	24	92	5,1
1 1/2	1R 307	1W 307	165	33	36,5	100	8,9
2	1B 308	1W 308	203	45	48	140	14,3

150 BOLTED & WELDED COVER

Reduced bore - Integral flanged ends

Reduced bore n°			A	B	B	C	Kg
Size	Bolted/B.	Welded/B.	End to end	Dia of port PISTON/BALL	Dia of port SWING	Center to top	Weight
1/2	1BR 303	1WR 303	108	9	10	70	2,8
3/4	1BR 304	1WR 304	118	12,5	10	80	4
1	1BR 305	1WR 305	127	17,5	18	92	5,3
1 1/2	1BR 307	1WR 307	165	29	29,5	100	9
2	1BR 308	1WR 308	203	35	36,5	140	15

300 BOLTED & WELDED COVER

Standard bore - Integral flanged ends

Standard bore n°			A	B	B	C	Kg
Size	Bolted/B.	Welded/B.	End to end	Dia of port PISTON/BALL	Dia of port SWING	Center to top	Weight
1/2	3B 303	3W 303	152,5	12	14	80	3
3/4	3B 304	3W 304	178	17,5	18	85	5,1
• 1	3B 305	3W 305	203	21	24	95	6
• 1 1/2	3B 307	3W 307	229	35	36,5	102	12,5
2	3B 308	3W 308	267	45	48	145	19

• For swing type end to end $\varnothing 1 - 216 \cdot \varnothing 1^{1/4} - 229 \cdot \varnothing 1^{1/2} - 241$

300 BOLTED & WELDED COVER

Reduced bore - Integral flanged ends

Reduced bore n°			A	B	B	C	Kg
Size	Bolted/B.	Welded/B.	End to end	Dia of port PISTON/BALL	Dia of port SWING	Center to top	Weight
1/2	3BR 303	3WR 303	152,5	9	10	50	2,8
3/4	3BR 304	3WR 304	178	12,5	14	55	4,7
• 1	3BR 305	3WR 305	203	17,5	18	70	5,7
• 1 1/2	3BR 307	3WR 307	229	29	30	98	11,8
2	3BR 308	3WR 308	267	35	36,5	110	17

• For swing type end to end $\varnothing 1 - 216 \cdot \varnothing 1^{1/4} - 229 \cdot \varnothing 1^{1/2} - 241$

600 BOLTED & WELDED COVER

Standard bore - Integral flanged ends

Standard bore n°			A	B	B	C	Kg
Size	Bolted/B.	Welded/B.	End to end	Dia of port PISTON/BALL	Dia of port SWING	Center to top	Weight
1/2	6B 303	6W 303	165	12	14	80	3,1
3/4	6B 304	6W 304	191	16	18	85	5,3
1	6B 305	6W 305	216	22	24	95	6,2
1 1/2	6B 307	6W 307	241	34	36	102	12,8
2	6B 308	6W 308	292	45	48	145	19,2

600 BOLTED & WELDED COVER

Reduced bore - Integral flanged ends

Reduced bore n°			A	B	B	C	Kg
Size	Bolted/B.	Welded/B.	End to end	Dia of port PISTON/BALL	Dia of port SWING	Center to top	Weight
1/2	6BR 303	6WR 303	165	9	10	50	2,9
3/4	6BR 304	6WR 304	191	12,5	14	55	4,8
1	6BR 305	6WR 305	210	17,5	18	70	9,7
1 1/2	6BR 307	6WR 307	241	29	30	98	12
2	6BR 308	6WR 308	292	35	36,5	110	17,3

1500 BOLTED & WELDED COVER

Standard bore - Integral flanged ends

Standard bore n°			A	B	B	C	Kg
Size	Bolted/B.	Welded/B.	End to end	Dia of port PISTON/BALL	Dia of port SWING	Center to top	Weight
1/2	15BF 303	15WF 303	216	11	14	90	7,6
3/4	15BF 304	15WF 304	229	14,5	18	105	10,8
1	15BF 305	15WF 305	254	19	24	120	14,5
1 1/2	15BF 307	15WF 307	305	31	36	160	31
2	15BF 308	15WF 308	368	37,5	40	170	43

2500 ROUND BOLTED & WELDED COVER

Standard bore - Integral flanged ends

Standard bore n°			A	B	B	C	Kg
Size	Bolted/B.	Welded/B.	End to end	Dia of port PISTON/BALL	Dia of port SWING	Center to top	Weight
1/2	25BF 303	25WF 303	264	10	10	105	9,8
3/4	25BF 304	25WF 304	273	14	14	110	11,8
1	25BF 305	25WF 305	308	19	19	125	16,5
1 1/2	25BF 307	25WF 307	384	28	30	160	37
2	25BF 308	25WF 308	451	35	36,5	170	58



PN 10÷16 BOLTED & WELDED COVER
Standard bore - Integral flanged ends
PN 25÷40 Welded Cover Fig. n° 2W 300 - 4W 300

Standard bore DN	Fig. n°		A End to end	B Dia of port	C Centre to top	Kg Weight
	PN 10÷16	PN 25÷40				
15	2B 303	4B 303	130	15	75	4
20	2B 304	4B 304	150	20	85	4,5
25	2B 305	4B 305	160	25	100	6,5
32	2B 306	4B 306	180	32	110	11
40	2B 307	4B 307	200	40	140	14
50	2B 308	4B 308	230	50	160	19

PN 10÷16 BOLTED & WELDED COVER
Reduced bore - Integral flanged ends
PN 25÷40 Welded Cover Fig. n° 2WR 300 - 4WR 300

Reduced bore DN	Fig. n°		A End to end	B Dia of port	C Centre to top	Kg Weight
	PN 10÷16	PN 25÷40				
15	2BR 303	4BR 303	130	9	85	3,8
20	2BR 304	4BR 304	150	12,5	90	4,4
25	2BR 305	4BR 305	160	17,5	100	6
32	2BR 306	4BR 306	180	22	112	8
40	2BR 307	4BR 307	200	29	145	13,7
50	2BR 308	4BR 308	230	35	145	14,2

PN 63÷160 BOLTED & WELDED COVER
Standard bore - Integral flanged ends

Standard bore DN	Fig. n°		A End to end	B Dia of port	C Centre to top	Kg Weight
	Bolted c. PN 63÷160	Welded c.				
15	7BR 303	7WR 303	210	12	68	5,8
20	7BR 304	7WR 304	230	17	92	10
25	7BR 305	7WR 305	230	22	98	12
32	7BR 306	7WR 306	260	24	105	16,5
40	7BR 307	7WR 307	260	29	140	16,5
50	7BR 308	7WR 308	300	31	148	19

PN 250 BOLTED & WELDED COVER
Standard bore - Integral flanged ends

Standard bore DN	Fig. n°		A End to end	B Dia of port	C Centre to top	Kg Weight
	Bolted c. PN 250	Welded c.				
15	18B 303	18W 303	230	11	90	5
20	18B 304	18W 304	260	12,5	100	7,5
25	18B 305	18W 305	260	17,5	100	9
40	18B 307	18W 307	310	29	140	18
50	18B 308	18W 308	350	37	150	25

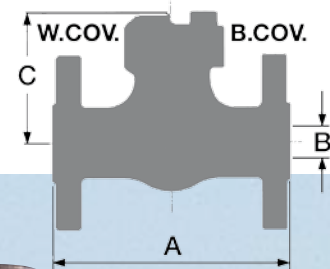

CHECK VALVES

Face to face DIN 3202

Flanges to
DIN 2635 - 2636 - 2637

Butt welding ends to
DIN 3239

