



Flow Control Division

Installation, Operating & Maintenance Instructions

Norbro Pneumatic Actuators

39R/40R Series Sizes 05, 10, 15, 20, 25, 30, 33, 35, 40 & 42

39/40 Series Sizes 45 & 50

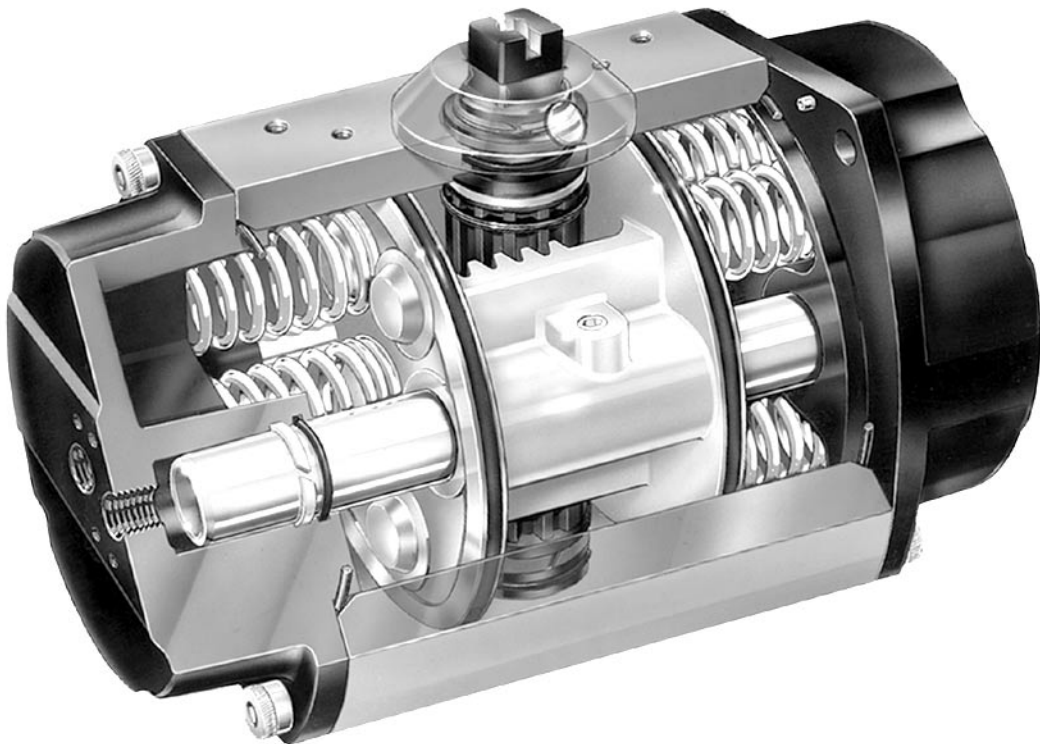

1 STORAGE AND PRESERVATION

When despatched, all actuators are prepared for storage. All protective packaging, end cap port plugs, pinion covers etc. should remain in position until the actuator is due to be installed.

Actuators should be stored in a clean, dry environment.

2 ACTUATOR MARKINGS

Each actuator has the following identification information on the product label attached to the side of the body:

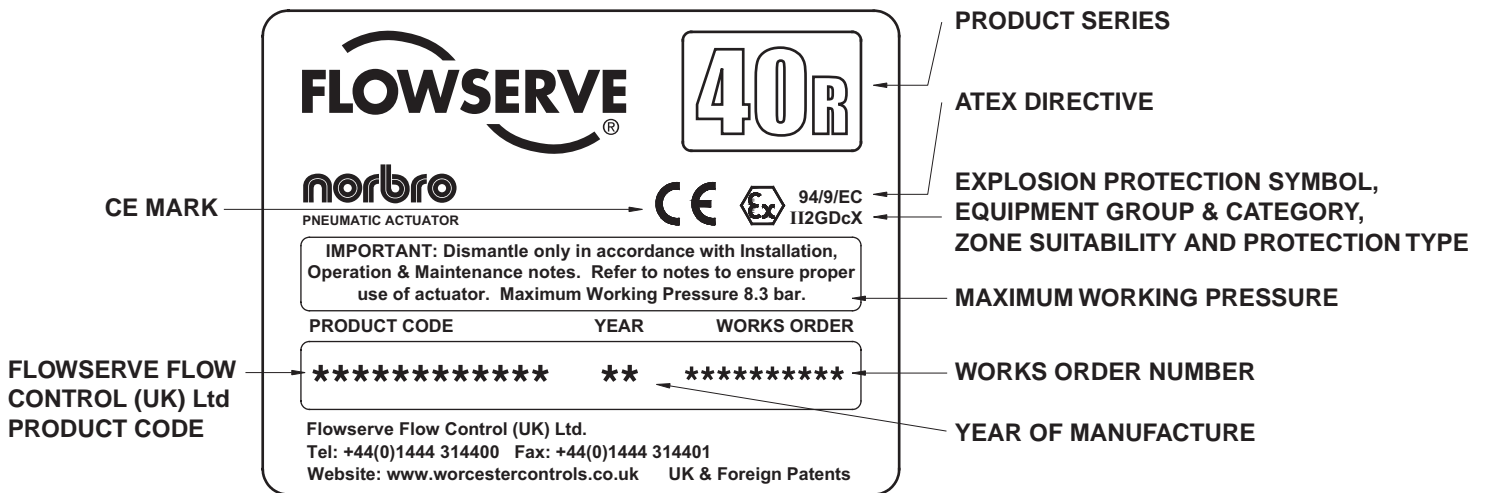

ATEX Directive: If the product label carries the ATEX Directive number '94/9/EC' followed by the Explosion Protection Symbol and codes identifying the equipment group and category, the zone suitability and protection type beside the CE mark, the product complies with the ATEX Directive and The Equipment and Protective Systems Intended for Use in Potentially Explosive Atmospheres Regulations 1996.

Definition of product label marking above:

'II' = Equipment Group; '2' = Equipment Category; 'G' = Gas Zone suitability (Zones 1 & 2); 'D' = Dust Zone suitability (Zones 21 & 22); 'c' = type of protection i.e. constructional safety (prEN 13463-5).

'X' = Special temperature reference (Surface Temperature: As per BS EN 13463-1:2001 paragraph 14.2g, the temperature class or maximum surface temperature cannot be marked on the product as it is dependant on the operating conditions).

The operational temperature range is as follows:

(S) Standard -20°C to +100°C.

(L) Low Temperature variant -40°C to +85°C.

(H) High Temperature variant -20°C to +150°C.

NOTE: Under constant use the surface temperature of exposed parts may rise by a maximum 20°C above the operating media temperature.

3 HEALTH AND SAFETY

When installing or maintaining actuators:

- a) Conduct a risk assessment and eliminate or reduce hazards to an acceptable level.
- b) Work in accordance with Safe Systems of Work.
- c) Observe all site Health and Safety Rules in particular Permit to Work and Hot Work procedures.
- d) Wear all necessary Personal Protective Equipment.
- e) Never remove or maintain an actuator or joint unless the supply has been fully de-pressurised, drained and where necessary, purged of toxic / explosive / flammable media. Always operate the actuator to ensure that no trapped pressure exists.
- f) Never handle actuators that have been used on harmful substances unless they have been completely decontaminated and certified safe to handle.
- g) Never use an actuator on a duty, which exceeds its prescribed operating parameters. Refer to Flowserve Flow Control (UK) Ltd. Technical Sales for further information.
- h) Never modify or alter actuators unless the manufacturer has been consulted and/or recommends such changes.
- i) Due to the large physical size and weight of some sizes of this product, always use correct lifting methods and equipment when installing, removing and maintaining the product, and that it is correctly supported in its final operating location.
- j) Due to the variety of duties on which this product can be employed, it is the end users responsibility to ensure the compatibility of the product with the specific application (i.e. air supply, torque, corrosion, which may effect it's suitability).
- k) Before equipment is installed in areas which may be subject to seismic activity or extreme climatic conditions consult Flowserve Flow Control (UK) Ltd. Technical Sales.
- l) If the processes or environments that the products are used in are likely to cause temperatures (high or low) that may cause injury to personnel if touched, then adequate insulation/protection must be fitted.
- m) If the equipment is to be used on unstable gas duty, ensure that the operational parameters as indicated on the product label cannot be exceeded.
- n) This equipment should be protected by other devices to prevent over-pressurisation. (i.e. caused by external fire etc).
- o) This equipment must be installed in a system that is designed to prevent excessive forces acting on the mounting kit, switch box/ positioner, connections etc.
- p) Care must be taken when removing the actuator or accessing the valve that the actuator does not unexpectedly operate due to the stored failsafe spring torque, causing personal injury.
- q) This equipment is not a safety device and must be controlled / guarded by other devices.
- r) Do not rub actuator with a dry cloth as this can cause a build up of static charge. Only clean with a damp cloth.

4 PREPARATION FOR INSTALLATION

The working area should be clean and clear of any debris that would contaminate the actuator.

When despatched, actuators contain a mineral oil grease, this will lubricate the actuator for life.

Special variants may contain other lubricants. An air lubricator may be used if desired.

Make sure air supply is clean and filtered before installation, to ANSI/ISA S7.0.01-1996 and does not exceed 8.3 bar.

NOTE: For size 45 and 50 actuators with limit stops, supply pressure not to exceed 6 bar, actuators to be spring return only.

5 INSTALLATION INSTRUCTIONS

5.1 GENERAL

Actuators may be installed in-line or cross-line (i.e. 90 degrees to the valve flow). They may be installed in any orientation, but the bracketry should be of sufficient strength to not distort. The actuator may be operated by a solenoid control valve directly mounted to the Namur interface on the actuator. Alternatively it may be piped from a remote control system.

5.2 MOUNTING ACTUATOR TO VALVE

Actuators are usually fitted with ISO5211 spigot and hole pattern. It is suggested that these are used in preference to any other mounting arrangement. The actuator can be mounted to the valve in either fail open or closed mode, by rotating the actuator or drive adaptor by 90° in relation to the valve. Before fitting the actuator ensure that both are orientated to achieve the correct operation. Loosely attach the actuator to the valve mounting kit with the all the retaining bolts finger tight. Operate the actuator to allow the valve and actuator to align correctly. If the alignment of the valve ball or plug is critical for flow, before fully tightening the retaining bolts rotate actuator body until optimum alignment is achieved. Tighten all retaining bolts fully.

5.3 ADJUSTING THE STROKE (WHERE LIMIT STOPS FITTED)

All actuators leave the factory with the travel stops set 0° and 90°. Fine tune the actuator travel to suit the valve using the travel stops in the end cap. The right hand stop adjusts the closed position of the actuator and the left hand stop adjusts the open position. Adjust the stroke by loosening the stop nut, turning the stop using an Allen key until the correct stop position is reached, then retighten the nut. **NOTE:** Over tightening will damage the seal! Turning the stop clockwise will reduce the stroke, turning anticlockwise will increase the stroke.

5.4 MOUNTING POSITIONER, SWITCHBOX ETC. TO ACTUATOR

The Namur (VDI/VDE 3845) hole pattern on the top of the actuator can be used to mount a positioner or switchbox to the actuator using the applicable bracketry. Loosely attach the positioner or switchbox, with bracketry, to the actuator with the all the retaining bolts finger tight. Operate the actuator to allow the positioner or switchbox and actuator to align correctly. Tighten all retaining bolts fully. Due to space restrictions the 05 actuator uses the ISO F03 hole pattern with M5 tappings for top mounting, and an M4 tapping in the top of the pinion.

5 INSTALLATION INSTRUCTIONS (Cont.)

5.5 SOLENOID CONTROL VALVE

Ensure solenoid control valve is correctly configured for a double acting (5/2) or spring return (3/2) actuator. Before fitting the solenoid valve, remove the plastic vent plug from the left hand port of the Namur interface on the end cap (or from the bottom port of the Namur manifold on the 05). Fit solenoid control valve to the Namur interface ensuring port 2 of the solenoid valve relates to the right hand port of the actuator. Fit foolproofing stud to ensure solenoid control valve is not fitted inverted if maintenance is carried out at a later stage. Exhaust ports should be fitted with an appropriate bug trap / silencer.

5.6 DIRECT AIR CONNECTION

If the actuator is not controlled by a direct mounting air supply, connect the opening air supply to the right hand Namur port (bottom port on the 05). If the actuator is double acting a connection to the closing air supply Namur port is also required. Spring return actuators are supplied with a vent plug already installed in the exhaust port.

5.7 HAZARDOUS OR CORROSIVE ENVIRONMENTS

If a spring return actuator is to be used in a corrosive atmosphere or an atmosphere which may ignite in compression, it is highly recommended to fit some form of device to prevent ingress of the atmosphere in to the spring chamber of the actuator. In the case of direct mounting, self-breathing Namur solenoid control valves are highly recommended.

In the case of direct air connection in a hazardous environment, the exhaust should be vented to a safe area.

For further information please contact Flowserve Flow Control (UK) Ltd.

5 INSTALLATION INSTRUCTIONS (Cont.)

5.7 INDICATOR FITTING INSTRUCTIONS - SIZES 10, 15, 20

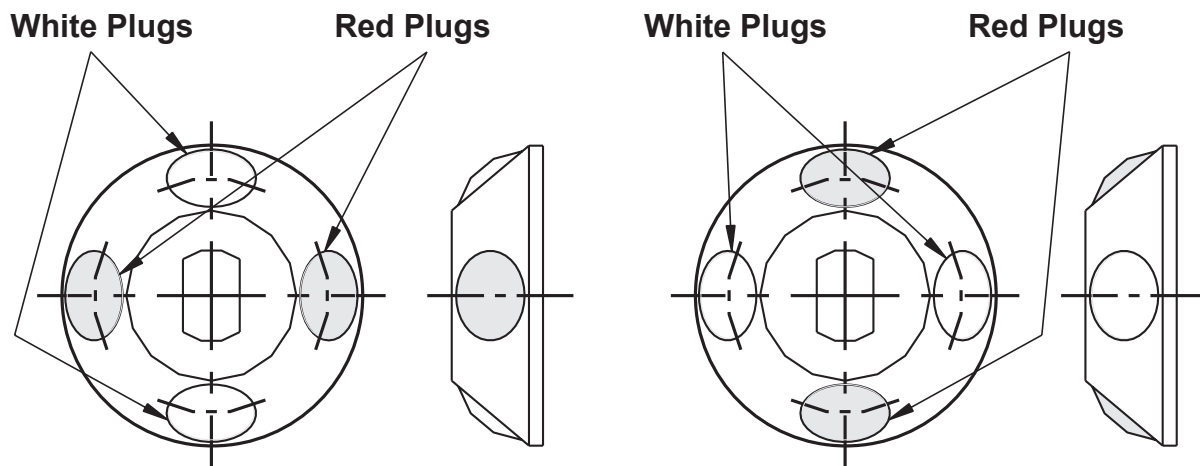

FIG.1 As supplied by Worcester Controls

FIG. 2 Alternative Indicating Position

NOTE: Indicator is set up to show pistons together on actuator, i.e. valve closed when in-line mounting - See Fig. 1.

- i) Check which visual indication is required.
- ii) Check that indicator when located on pinion will show correct indication.
- iii) To change indication, push out red and white buttons and reassemble in alternative
- iv) Locate indicator on pinion flats. Press firmly until location nibs fit into recess on pinion.

INDICATOR FITTING INSTRUCTIONS - SIZES 25, 30, 33, 35, 40, 42, 45, 50

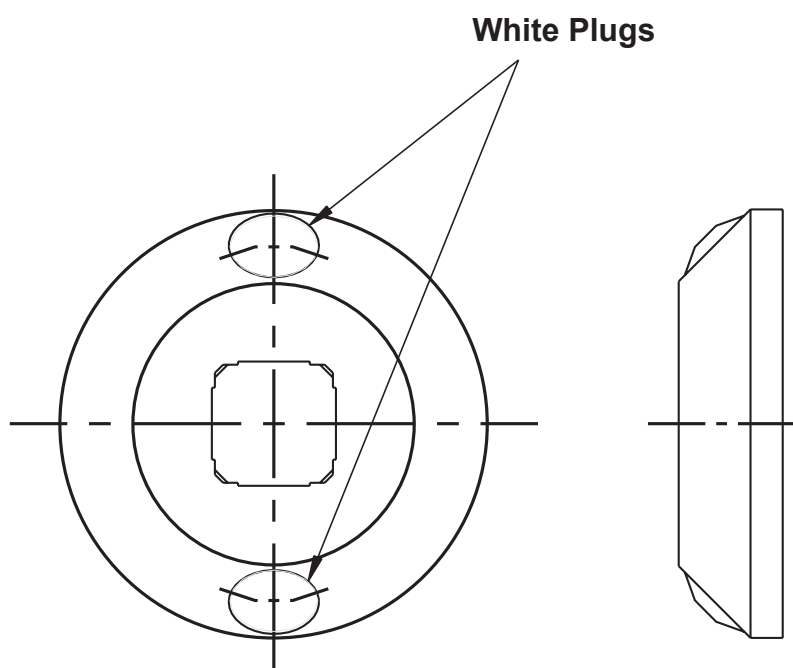

- i) Check which visual indication is required.
- ii) Locate indicator on pinion flats. Press firmly until location nibs fit into recess on pinion.

6 OPERATION

6.1 GENERAL

Viewed from the top, actuators rotate in anti-clockwise direction when the supply port centre chamber is pressurised.

All sizes have an overall rotational range of 90° with average 1° overtravel anti-clockwise and average 1° overtravel clockwise.

OPERATIONAL SEQUENCE 10 - 50

Double Acting

Pistons Together

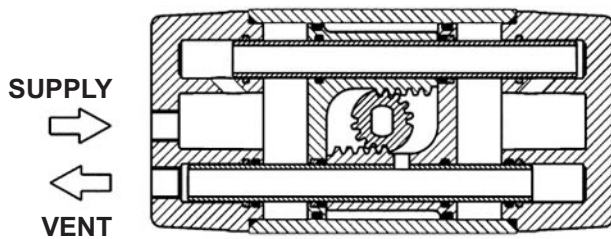

Pistons Apart

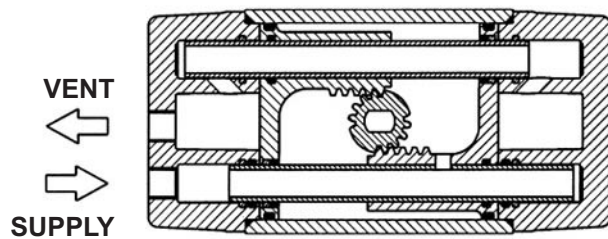

Spring Return

Pistons Together

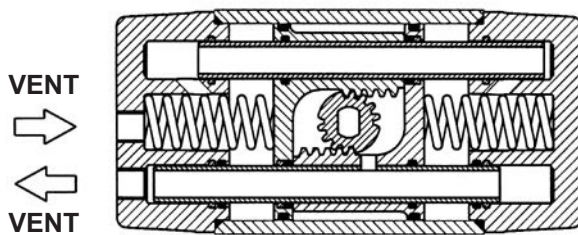

Pistons Apart

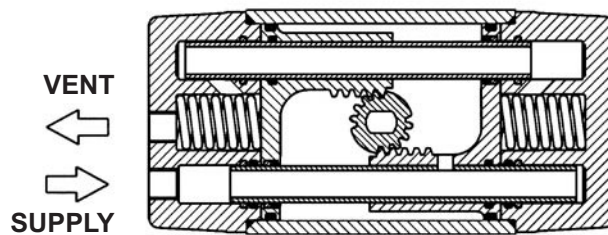

6 OPERATION (Cont.)

OPERATIONAL SEQUENCE 05

Double Acting

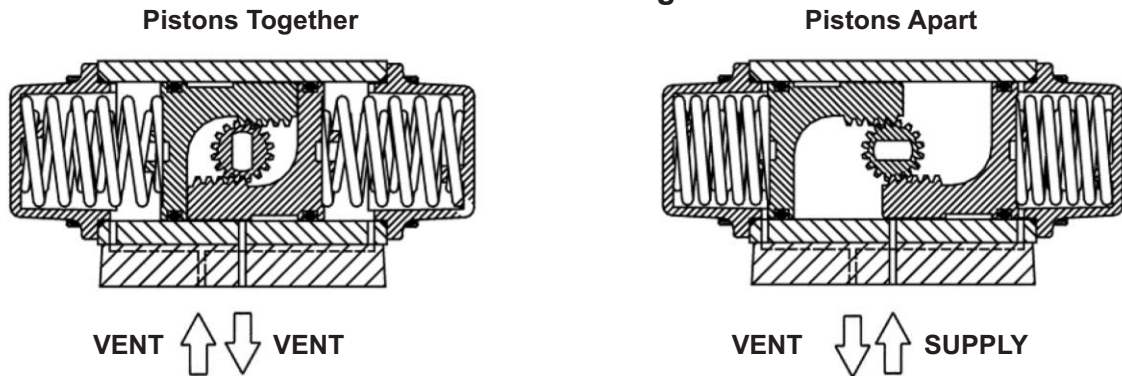

Spring Return

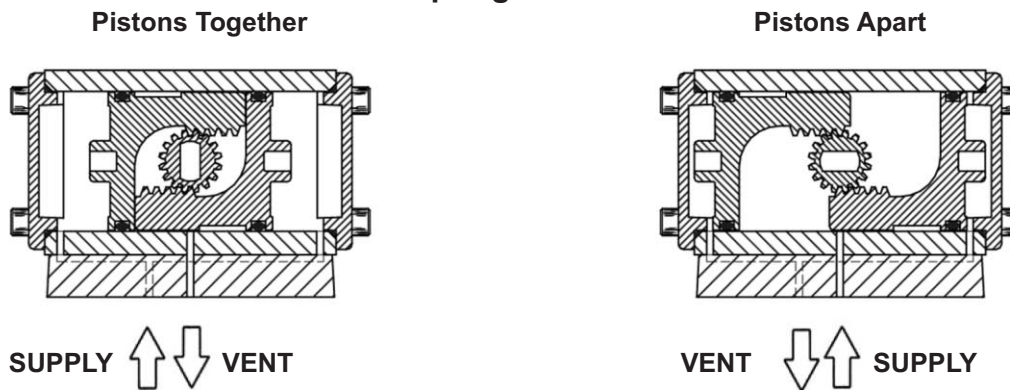

6.2 AIR SUPPLY

All standard actuators operate satisfactorily with an air line pressure of up to 8.3bar (120 psi). The actuator will however, have been sized with regard to the torque required to open or close the valve at a particular pressure. Care must be taken to ensure that actual operating pressure is that which is specified. Supply air must be to the ANSI/ISA S7.0.01-1996 instrument air quality standard.

All actuators are supplied with sufficient lubrication for a normal working life. For extreme life cycle applications, the use of lubricated air supply is recommended.

NOTE: For ATEX compliance, when used in explosive atmospheres Non Corrosive and/or Non Explosive gases or liquids **MUST** be used as an operating medium.

7 MAINTENANCE

7.1 GENERAL

Norbro actuators are designed to have long, trouble free lives and maintenance is seldom needed.

The following checks will help extend life further and reduce plant problems:

Routine checks / maintenance:

- i) Every 25000 cycles or 3 months: Check for any signs of leakage (see 7.2) and that all retaining fasteners are secure. The maximum permissible leakage rate for a new actuator is a one inch diameter soap bubble in five seconds (1.7ml per second) when pressurised at 5.5 bar (80 psi). However leakage in excess of this may not affect performance.
- ii) Infrequent operation: The actuator should not be left standing without operation for more than 1 month. After this period the actuator should be operated through three full cycles.

Where actuators are used in hazardous areas (ATEX Directive) we recommend that the springs in spring return actuators be replaced after one million operations.

NOTE: Do not rub actuator with a dry cloth as this can cause a build up of static charge. Only clean with a damp cloth

7.2 LEAK TESTING

- i) With only one air-line attached to the inlet port, check the leak rate at the opposite port when air is applied.
- ii) Check for leakage on the top and bottom of the pinion by brushing a soap solution on the joint areas with air applied to the centre chamber (air-line connected to right hand port of actuator).

NOTE: The following tests are only required for double acting actuators.

- iii) Reverse the air connections and check for leakage in the opposite direction.
- iv) Check there is no leakage between the end cap and the body by brushing a soap solution on the joint areas with air applied to the outside chambers (air-line connected to the left hand port of actuator).

8 REFURBISHMENT INSTRUCTIONS

Repair kits are available for all Norbro actuators. The kits contain replacements for all parts subject to wear.

If other parts are required, it is usually recommended that the complete actuator be replaced (although piece parts are available).

Only Norbro authorised spare parts should be used. This includes basic components such as fastenings. If the actuator is altered in any way without the consent of Flowserve Flow Control (UK) Ltd. then Flowserve Flow Control (UK) Ltd. will accept no responsibility.

Prior to commencing any work on the actuator or removing it from line:

- a) Refer to the 'Health & Safety' Instructions.
- b) For full refurbishment and lubrication instructions please refer to the instructions contained in the repair kits available from Flowserve Flow Control (UK) Ltd.
- c) Never remove or maintain an actuator unless the supply air has been disconnected and the actuator cycled to release residual air contained in the actuator. This will stop the actuator from unexpectedly operating.
- d) Note the orientation of the valve, mounting kit, actuator and positioner / switchbox in order to guarantee correct operation on reassembly.

9 REVERSE ACTING MODIFICATION

Reverse acting is only necessary when anti-clockwise "failure stroke" is essential.

When actuator is assembled for "reverse acting" **NOTE:**

- i) The pinion slot will lie "in line" with the actuator centre line.
- ii) The final rest position may be offset according to the table (right).
- iii) Alternative reverse acting pinions are available to correct any offset.

Actuator Size	Angle #
05	0°
10	10°
15	2°
20	2°
25	2°
30	2°
33	2°
35	2°
40	13°
42	0°
45	0°
50	12°

Reverse Acting 10-42

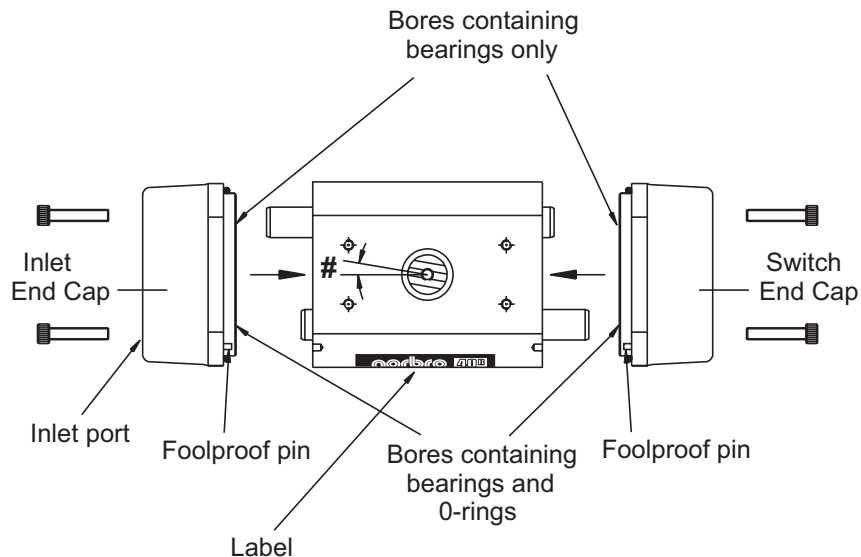
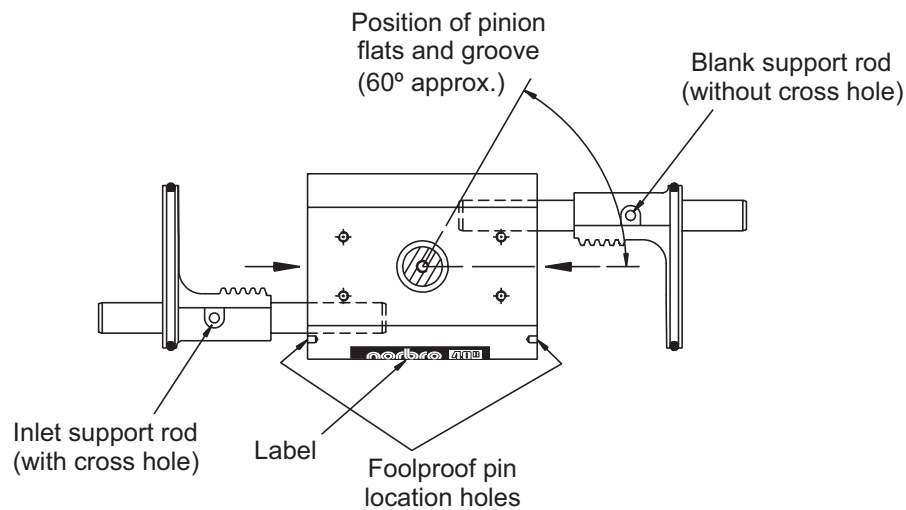

9 REVERSE ACTING MODIFICATION (Cont.)

Reverse Acting 05

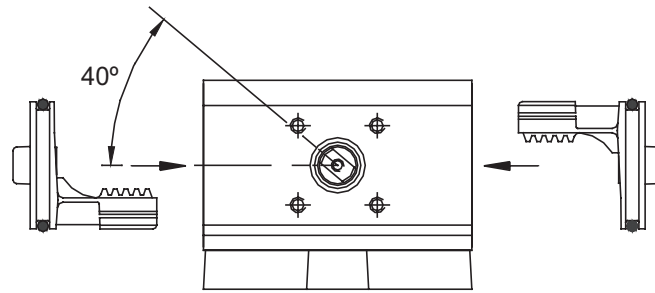

Pinion engagement position
for insertion of pistons

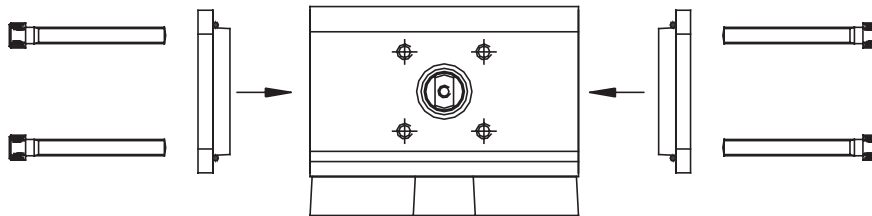

Pistons together
(fully Anti-Clockwise)



Flow Control Division

Flowserve Flow Control (UK) Ltd.

Burrell Road, Haywards Heath,
West Sussex RH16 1TL, England.

Telephone: +44 (0)1444 314400

Telefax: +44(0)1444 314401

Website: www.flowserve.com

Published and Printed by Flowserve Flow Control (UK) Ltd.
Information given in this leaflet is made in good faith and based upon specific testing but does not, however constitute a guarantee.