

rotork®

Gears

ILG-D Series

Cast Iron Housing
Declutchable Gear Operators

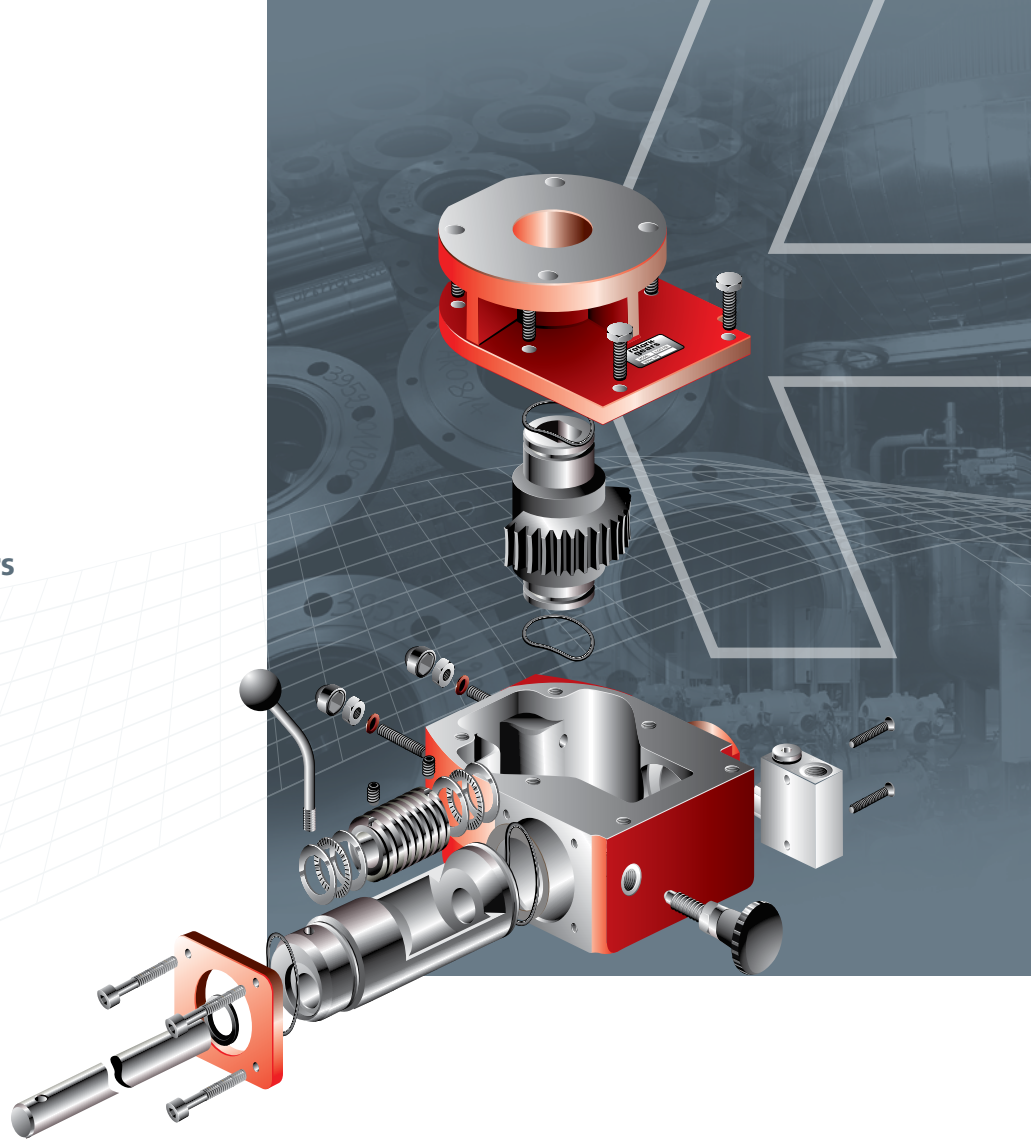

ILG-D Series Gear Operators

The Rotork Gears ILG-D gear operators are designed to provide a means of manually overriding pneumatic valve actuators in power and process applications. These gear operators employ a declutchable design for use with double acting actuators. To ensure long life, the housing is sealed to IP65 and the input shaft is made from Protected Steel.

Application

The Rotork Gears series ILG-D operators are used in all industries where reliable manual operation of double acting actuators is required. All units mount between the valve and actuator and may be supplied with an ISO drive shaft.

As an option, a 3/2 spool valve can be fitted, to automatically evacuate air from the actuator when the manual override lever is engaged.

Features

- Protected input shaft
- Cast iron housing
- Rugged construction
- Axial needle bearings
- Sealed to IP65
- Polyurethane coating
- Integral top flange (ISO drive coupling available if required)

Options

- 3/2 Relief valve
- Stainless Steel input shafts
- IP67 & IP68 enclosure (without 3/2 Relief valve)
- High and Low temperature ranges (without 3/2 Relief valve)
- Marinised Duty
- Flexible Extensions.

Performance Specification

- Stroke: 0 - 90° (± 5° adjustable)
- Enclosure: Sealed to IP65
- No. of Models: 9
- Torque Range: 150 to 17000 Nm (1330 to 150,460 lbf.in)
- Temperature: -20 to +120 °C (-4 to +250 °F)

Keeping the World Flowing

rotork® Gears

Type	Ratio	Torque Nm (lbf. inch)		M.A. ± 15%	Weight kg (lb)
		Output	Input		
ILG-D 100	40:1	150 (1330)	13 (115)	11	4,7 (10,4)
ILG-D 200	35:1	250 (2210)	26 (230)	9.5	7,3 (16,2)
ILG-D 600	46:1	750 (6640)	60 (530)	12.4	17 (37,7)
ILG-D 900	43:1	1450 (12832)	125 (1105)	11.6	21 (46,2)
ILG-D 1500	57:1	2485 (22000)	160 (1420)	15.4	34 (75,6)
ILG-D 2400	68:1	3390 (30000)	188 (1665)	18	54 (118,8)
ILG-D 5000	104:1	7450 (66000)	298 (2640)	25	80 (178)
ILG-D 8000/PR3	312:1	8135 (72000)	120 (1062)	68	90 (200)
ILG-D 16000/PR6	468:1	17000 (150460)	140 (1240)	121	90 (200)

Note: Because of the company's policy of continuous improvement, Rotork Gears reserves the right to change specification details without prior notice. The static safety factor is 1.5. The published M.A. is achieved after a few cycles.

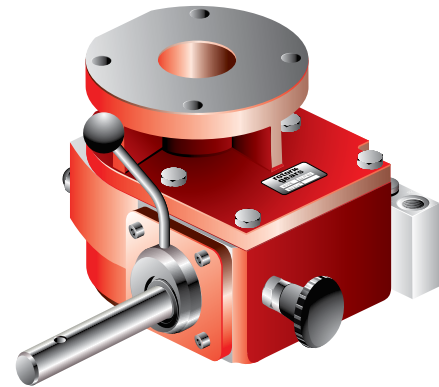

Material specification for Rotork ILG-D Series Gear Operators

No.	Description	Material	Notes
1	Body	Cast Iron	GG25 / ASTM A48-40
2	Coverplate	Cast Iron	GG25 / ASTM A48-40
3	Quadrant	Ductile Iron	GGG40 / ASTM D60-40-18
4	Worm	Carbon Steel	C45 / AISI 1045
5	Shaft	Protected Steel	-
6	Ball knob	Plastic	PF/ Fs 31
7	Hex head bolt	Steel	8.8 / DIN 933
8	O-ring	NBR	70
9	Blanking plug	Id-Polyethylene	-
10	Needle bearing	Hardened Steel	-
11	Bearing disk	100 Cr 6	-
12	Set screw	Steel	12.9 / DIN 915
13	Oil-seal	NBR	70
14	Hex socket head cap screw	Steel	8.8 / DIN 912
15	Spring lock washers	Steel zinc plated	DIN 125A
16	Set screw	Steel	8.8 / DIN 916
17	Hex nut	Steel zinc plated	DIN 934
18	Retaining ring	Polyamide	-
19	Nut protection cap	LDPE	-
20	Hex nut	Stainless Steel	DIN 439B
21	Stud	Stainless Steel	DIN 938
22	Latchbolt + nut	Stainless Steel / Plastic	-
23	Copperring	Copper	DIN 7603A
24	Grease	Renolit CLX2	-
25	Excentric rack	Cast Iron	GG25 / ASTM A48-40
26	Rackholder plate	Cast Iron	GG25 / ASTM A48-40
27	Label	Polyester	-
28	Gasket rackholder	NBR	65° Shore
29	Gasket coverplate	Liquid seal	-
30	Thrust bearing front	PTFE	-
31	Thrust bearing back	PTFE	-
32	Dowel pin	Steel	DIN 7603A
33	Coupling	42CrMO4 / 42CrMO	-
34*	PAP Bush	PTFE / Steel	-
35*	Dowel	Steel	DIN 6325
36*	o-ring	NBR	70
37*	Carrier	Steel	-
38*	Dowel	Steel	DIN 6325
39*	Planet gear	Hardened Steel	-
40*	O-ring	NBR	70
41*	Sun gear	Hardened Steel	-
42*	Input shaft	Stainless steel	-
43*	Lip seal	NBR	70
44*	Cover	Ductile iron	GGG40 / ASTM D60-40-18
45*	Hex socket head cap screw	Steel	8.8 / DIN 916
46*	Reducer Housing	Ductile iron	GGG40 / ASTM D60-40-18
47*	Key	Steel	-
48*	Spring lock washer	Steel	DIN 125A

NOTE: Ductile Iron housing is optional. Parts marked "*" are present in the ILG-D5000 and ILG-D16000 only.

Keeping the World Flowing

ILG-D Series

Cast Iron Housing Declutchable Gear Operators

Gearbox ILG-D Series

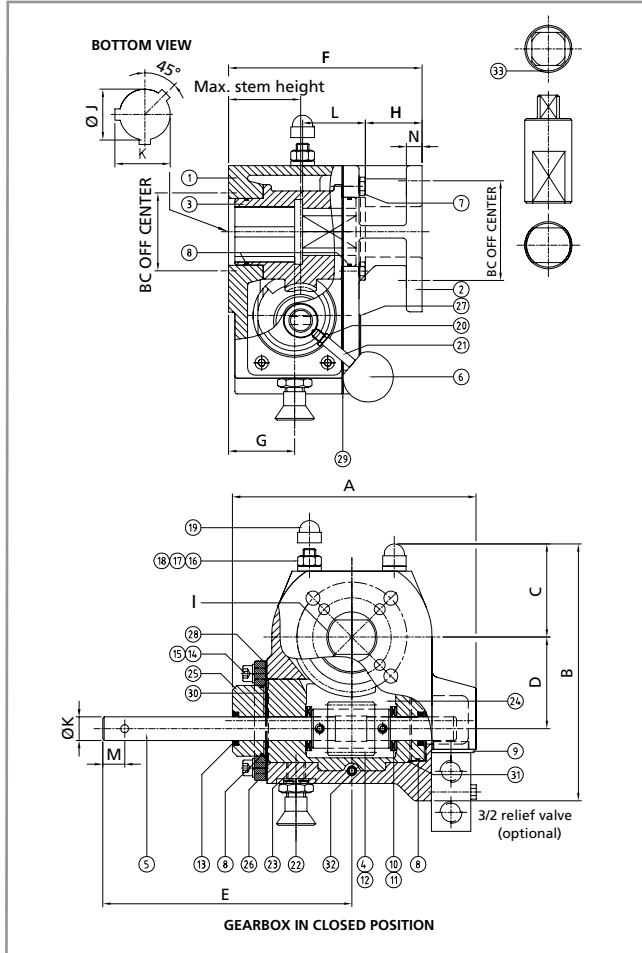

Type	Maximum bore				Max. stem height
	Insert		Quadrant*		
	Φ	□	Φ	□	
ILG-D 100	16 (0,63)	15 (0,59)	25 (0,98)	22 (0,87)	39 (1,53)
ILG-D 200	20 (0,79)	17 (0,67)	32 (1,26)	24 (0,94)	45 (1,77)
ILG-D 600	30 (1,18)	27 (1,06)	45 (1,77)	36 (1,42)	58 (2,28)
ILG-D 900	40 (1,57)	34 (1,33)	55 (2,17)	46 (1,81)	66 (2,60)
ILG-D 1500	44 (1,73)	36 (1,42)	60 (2,36)	50 (1,97)	71 (2,80)
ILG-D 2400	55 (2,20)	46 (1,81)	75 (2,95)	60 (2,36)	92 (3,62)
ILG-D 5000	70 (2,76)	55 (2,17)	95 (3,74)	75 (2,95)	113 (4,45)
ILG-D 8000/PR3	70 (2,76)	55 (2,17)	95 (3,74)	75 (2,95)	113 (4,45)
ILG-D 16000/PR6	90 (3,54)	75 (2,95)	140 (5,51)	110 (4,33)	90 (3,54)

*Optional max. Valve bores (into the quadrant without insert).
Inserts are not retained in the gearbox, please specify if required.

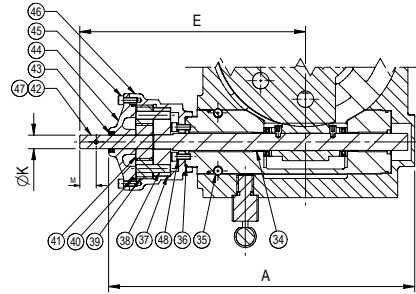

Type	A	B	C	D	E	F	G	ØK	M	N	Valve Connection	Act. Connection
ILG-D 100	157 (6,16)	145 (5,69)	45 (1,76)	42,5 (1,67)	137,5 (5,39)	101 (3,96)	34 (1,33)	12 (0,47)	14 (0,55)	8 (0,31)	F05/F07	F05/F07
ILG-D 200	155 (6,11)	165 (6,52)	61 (2,41)	53,2 (2,10)	158 (6,24)	122 (4,82)	42 (1,66)	15 (0,59)	14 (0,55)	10 (0,40)	F05/F07/F10	F05/F07
ILG-D 600	194 (7,64)	210 (9,02)	94,5 (3,74)	64,5 (2,55)	189,5 (7,49)	145 (5,73)	51 (2,02)	15 (0,59)	14 (0,55)	12 (0,47)	F07/F10/F12	F07/F10/F12
ILG-D 900	223 (8,78)	236,5 (9,31)	90 (3,54)	84,5 (3,33)	190 (7,48)	160 (6,30)	56,5 (2,22)	20 (0,79)	24 (0,94)	13 (0,51)	F10/F12/F14	F10/F12/F14
ILG-D 1500	250 (9,84)	286 (11,26)	118,5 (4,67)	107,5 (4,23)	233 (9,16)	175 (6,89)	55 (2,17)	20 (0,79)	24 (0,94)	20 (0,79)	F10/F12/F14/F16	F12/F14/F16
ILG-D 2400	280 (11,02)	327 (12,87)	123 (4,84)	127 (5,00)	244 (9,61)	194 (7,64)	62 (2,44)	25 (0,98)	28 (1,10)	15 (0,59)	F12/F14/F16	F14/F16
ILG-D 5000	345 (13,58)	386 (15,20)	150 (5,91)	155 (6,10)	275,5 (10,85)	209 (8,23)	72 (2,83)	25 (0,98)	28 (1,10)	15 (0,59)	F16/F25	F16/F25
ILG-D 8000	448,5 (17,65)	386 (15,20)	150 (5,91)	155 (6,10)	330 (12,99)	209 (8,23)	72 (2,83)	20 (0,79)	24 (0,94)	15 (0,59)	F16/F25	F16/F25
ILG-D 16000	430 (16,93)	436 (17,17)	168,5 (6,63)	182 (7,16)	347,5 (13,68)	229 (9,01)	69 (2,40)	20 (0,79)	28 (1,10)	17 (0,67)	F25/F30	F25/F30

Type	H	I (prep. for coupling)	J (insert outside diameter)	K	L(max)
ILG-D 100	29,5 (1,16)	DD20 (0,79) x 14 (0,55)	Ø25 (0,98) key 6,35 (0,25)	27,5 (1,08)	30,5 (1,20)
ILG-D 200	41 (1,61)	DD22 (0,87) x 30 (1,18)	Ø32,15 (1,27) key 6,35 (0,25)	35,5 (1,40)	34 (1,34)
ILG-D 600	28 (1,11)	DD25 (0,98) x 35 (1,38)	Ø45,3 (1,78) key 10 (0,39)	48,6 (1,91)	57 (2,24)
ILG-D 900	27 (1,06)	DD35 (1,38) x 50 (1,97)	Ø54 (2,13) key 16 (0,63)	58,3 (2,30)	64 (2,52)
ILG-D 1500	26 (1,02)	DD45 (1,77) x 60 (2,36)	Ø60 (2,36) key 18 (0,71)	64,4 (2,54)	72 (2,83)
ILG-D 2400	32 (1,26)	DD50 (1,97) x 74 (2,91)	Ø75 (2,95) key 22 (0,87)	79,9 (3,15)	63 (2,48)
ILG-D 5000	13 (0,51)	DD60 (2,36) x 80 (3,15)	Ø90 (3,54) key 32 (1,26)	97,4 (3,83)	75 (2,95)
ILG-D 8000	13 (0,51)	DD60 (2,36) x 80 (3,15)	Ø90 (3,54) key 32 (1,26)	97,4 (3,83)	75 (2,95)
ILG-D 16000	95 (3,74)	Ø140 (5,51) x 32 (1,26) Key	Ø140 (5,51) x key 32 (1,26)	147,6 (5,81)	-

All dimensions in millimetres (inches).

Handwheel Selection Chart

Input Torque

Type	M.A. ± 15%
ILG-D 100	11
ILG-D 200	9.5
ILG-D 600	12.4
ILG-D 900	11.6
ILG-D 1500	15.4
ILG-D 2400	18
ILG-D 5000	25.0
ILG-D 8000/PR3	68
ILG-D 16000/PR6	121

Dimensions

Type	A	B
PS100-12	Ø100 (4)	35 (1,38)
PS125-12	Ø125 (5)	34 (1,34)
PS125-15		48 (1,89)
PS160-12	Ø160 (6)	48 (1,89)
PS160-15		49 (1,93)
PS200-12	Ø200 (8)	51 (2,00)
PS200-15		52 (2,05)
PS200-20		63 (2,48)
PS250-12	Ø250 (10)	63 (2,48)
PS250-15		63 (2,48)
PS250-20		70 (2,76)

Type	A	B
SG200	Ø200 (8")	80 (3,15")
SG250	Ø250 (10")	110 (4,33")
SG300	Ø300 (12")	115 (4,53")
SG350	Ø350 (14")	120 (4,72")
SG400	Ø400 (16")	130 (5,12")
SG450	Ø450 (18")	150 (5,91")
SG500	Ø500 (20")	150 (5,91")
SG600	Ø600 (24")	150 (5,91")
SG700	Ø700 (28")	150 (5,91")
SG800	Ø800 (32")	150 (5,91")
SG900	Ø900 (36")	160 (6,30")
SG1000	Ø1000 (40")	160 (6,30")

